



Overseas Affiliates

U.S.A.

RICOH CORPORATION
5 Dedrick Place
West Caldwell, New Jersey
07006
Phone: +1-973-882-2000

Spain

RICOH ESPAÑA S.A.
Avda. Litoral Mar, 12-14,
08005 Barcelona
Phone: +34-(0)93-295-7600

The Netherlands

RICOH EUROPE B.V.
Groenelaan 3, 1186 AA,
Amstelveen
Phone: +31-(0)20-5474111

Italy

RICOH ITALIA SpA
Via della Metallurgia 12,
37139 Verona
Phone: +39-(0)45-8181500

United Kingdom

RICOH UK LTD.
Ricoh House,
1 Plane Tree Crescent,
Feltham,
Middlesex, TW13 7HG
Phone: +44-(0)181-261-4000

Hong Kong

RICOH HONG KONG LTD.
23/F., China Overseas
Building,
139, Hennessy Road,
Wan Chai, Hong Kong
Phone: +852-2862-2888

Germany

RICOH DEUTSCHLAND
GmbH
Mergenthalerallee 38-40,
65760 Eschborn
Phone: +49-(0)6196-9060

Singapore

RICOH ASIA PACIFIC
PTE.LTD.
260 Orchard Road,
#15-01/02 The Heeren,
Singapore 238855
Phone: +65-830-5888

France

RICOH FRANCE S.A.
383, Avenue du Général
de Gaulle
BP 307-92143 Clamart
Cedex
Phone: +33-(0)1-40-94-38-38

SUPPLIES MODEL NAME

The correct model name of supplies for
your Bizworks is:
RICOH TONER CASSETTE TYPE 1120D BLACK

RICOH CO., LTD.

15-5, 1 chome, Minami-Aoyama, Minato-ku, Tokyo,
Phone: Tokyo 3479-3111

Printed in China

UE G027-8647



Operation Manual

RICOH

RICOH
Bizworks™
706

Operation Manual

Read this manual carefully before you use this product and keep it handy for future reference. For safety, please follow the instructions in this manual.

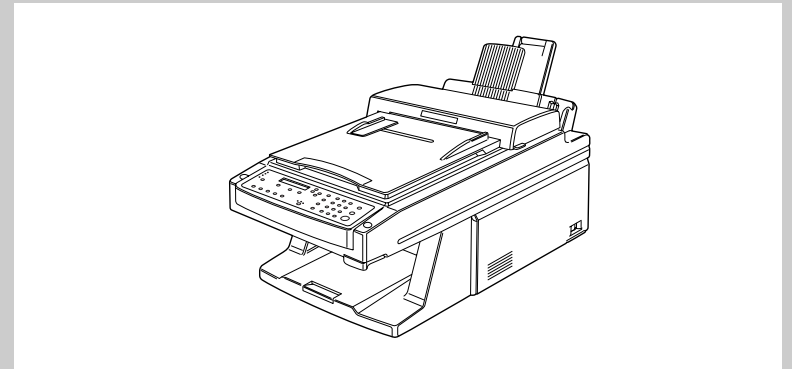

**RICOH CORPORATION
CALLING FOR SERVICE**

For service in the United States, call:
1-800-RICOH38 (1-800-742-6438)

Introduction

This manual contains detailed instructions on the operation and maintenance of this machine. To get maximum versatility from this machine, all operators should carefully read and follow the instructions in this manual. Please keep this manual in a handy place near the machine. Please read the safety information on pages i - iii of this manual. It contains Important Information related to user safety and preventing equipment problems.

Laser Safety:

The optical housing unit can only be repaired in a factory or at a location with the requisite equipment. The laser subsystem is replaceable in the field by a qualified Customer Engineer. The laser chassis is not repairable in the field. Customer engineers are therefore directed to return all chassis and laser subsystems to the factory or service depot when replacement of the optical subsystem is required.

Notes:

- Model names for the machines do not appear in the following pages. Check the type of your machine before reading this manual.
Bizworks 706
- Some illustrations may be slightly different from your machine.
- Certain types may not be available in some countries. For details, contact your local dealer.

Two kinds of size notation are employed in this manual. With this machine refer to the metric version.

For good print quality, Ricoh recommends that you use genuine Ricoh toner.

Ricoh shall not be responsible for any damage or expense that may result from the use of parts other than genuine Ricoh parts in your Ricoh office product.

Power Source: 120 V, 60 Hz, 4.2 A

Please make sure to connect the power cord to a power source as above. For details about power connection, refer to page 8.

Trademarks

Microsoft, Windows, and MS-DOS are registered trademarks of Microsoft Corporation in the United States and/or other countries. Other product names used herein are for identification purposes only and might be trademarks of their respective companies. We disclaim any and all rights in those marks.

In accordance with ISO Standard 7001, this machine uses the following symbols for the main switch:

- ⏻ means POWER ON.
- ⏻ means POWER OFF.

INFORMATION TO THE USER

USA FCC Part 15 Class B

NOTE

This equipment has been tested and found to comply with the limits for a Class B digital device, pursuant to Part 15 of the FCC Rules. These limits are designed to provide reasonable protection against harmful interference in a residential installation. This equipment generates, uses and can radiate radio frequency energy and, if not installed and used in accordance with the instructions, may cause harmful interference to radio communications.

However, there is no guarantee that interference will not occur in a particular installation.

If this equipment does cause harmful interference to radio or television reception, which can be determined by turning the equipment off and on, the user is encouraged to try to correct the interference by one or more of the following measures:

- Reorient or relocate the receiving antenna.
- Increase the separation between the equipment and receiver.
- Connect the equipment into an outlet on a circuit different from that to which the receiver is connected.
- Consult the dealer or an experienced radio/TV technician for help.

Properly shielded and grounded cables and connectors must be used for connections to host computer in order to meet FCC emission limits.

WARNING

Changes or modifications not expressly approved by the party responsible for compliance could void the user's authority to operate the equipment.

COMPLIANCE INFORMATION STATEMENT

Declaration of Conformity

RICOH Bizworks
406/406DF
RICOH CORPORATION
5 Dedrick Place West Caldwell, New Jersey 07006
973-882-2000

This device complies with Part 15 of the FCC Rules. Operation is subject to the following two conditions: (1) This device may not cause harmful interference, and (2) this device must accept any interference received, including interference that may cause undesired operation.

CANADA Class B

This Class B digital apparatus complies with Canadian ICES-003.
Cet appareil numérique de la classe B est conforme à la norme NMB-003 du Canada.

Safety Information

When using your machine, the following safety precautions should always be followed.

Types of warnings used in this manual



WARNING

Ignoring this warning could cause serious injury or even death.



CAUTION

Ignoring this caution could cause injury or damage to property.

Symbol examples



The  symbol means a situation that requires you take care.



The  symbol means you **MUST NOT** carry out this operation. This example means "Do not take apart."









The  symbol means you **MUST** perform this operation. This example means "You must remove the wall plug."







Microsoft®, Windows®, and MS-DOS® are registered trademarks of Microsoft Corporation in the United States and/or other countries.

Other product names used here in are for identification purposes only and might be trademarks of their respective companies. We disclaim any and all rights in those marks.

WARNING:

	<ul style="list-style-type: none">• Use of controls or adjustment or performance of procedures other than those specified in this manual may result in hazardous radiation exposure.
	<ul style="list-style-type: none">• Only connect the machine to the power source described on the inside of the front cover.• Avoid multi-wiring.• Do not damage, break or make any modifications to the power cord. Do not place heavy objects on it, pull it hard or bend it more than necessary. These actions could cause an electric shock or fire.• Do not plug or unplug the power cord with your hands wet. Otherwise, an electric shock might occur.
	<ul style="list-style-type: none">• Make sure the wall outlet is near the machine and freely accessible so that in event of an emergency it can be unplugged easily.
	<ul style="list-style-type: none">• Do not remove any covers or screws other than those specified in this manual. Some parts of the machine are at a high voltage and could give you an electric shock. Also, reflected eye contact with the laser beam may cause serious eye damage. When the machine needs to be checked, adjusted, or repaired, contact your service representative.• Do not take apart or attempt any modifications to this machine. There is a risk of fire, electric shock, explosion or loss of sight.
	<ul style="list-style-type: none">• If the machine looks damaged or breaks down, smoke is coming out, there is a strange smell or anything looks unusual, immediately turn off the power switch then unplug the power cord from the wall. Do not continue using the machine in this condition. Contact your service representative.• If metal, liquid or foreign matter falls into the machine, turn off the power switch, and unplug the power cord. Contact your service representative. Do not keep using the machine with a fault or defect.
	<ul style="list-style-type: none">• Do not put any metal objects or containers holding water (e.g. vases, flower-pots, glasses) on the machine. If the contents fall inside the machine, a fire or electric shock could occur.
	<ul style="list-style-type: none">• Do not incinerate used toner or toner cassettes. Toner dust might ignite when exposed to an open flame. Dispose of the used toner cassettes according to local regulations for plastics.

CAUTION:

	<ul style="list-style-type: none">• Keep the machine away from humidity and dust. A fire or an electric shock might occur.• Do not place the machine on an unstable or tilted surface. If it topples over, it could cause injury.
	<ul style="list-style-type: none">• When you move the machine, unplug the power cord from the wall outlet to avoid fire or electric shock.• When the machine is not be used for a long time, unplug the power cord.
	<ul style="list-style-type: none">• When you pull out the plug from the socket, grip the plug to avoid damaging the cord and causing fire or electric shock.
	<ul style="list-style-type: none">• If you use the machine in a confined space, make sure there is a continuous air turnover.
	<ul style="list-style-type: none">• Do not reuse stapled paper. Do not use aluminium foil, paper containing carbon or any other conductive paper. Otherwise, a fire might occur.
	<ul style="list-style-type: none">• When removing misfed paper, or replacing the toner cassette and the cleaning pad, do not touch the fusing section because it could be very hot.
	<ul style="list-style-type: none">• This machine has been tested for safety using this supplier's parts and consumables. We recommend you only use these specified supplies.

Energy Star program

Energy Star®



As an Energy Star partner, we have determined that this machine model meets the Energy Star Guidelines for energy efficiency.

The Energy Star Guidelines intend to establish an international energy-saving system for developing and introducing energy-efficient office equipment to deal with environmental issues, such as global warming.

When a product meets the Energy Star Guidelines for energy efficiency, the Partner shall place the Energy Star logo onto the machine model.

This product was designed to reduce the environmental impact associated with printing equipment by means of energy-saving features such as Low Power mode.

- **Low Power Mode**

This machine automatically lowers its power consumption 15 minutes after the last printing job has been completed. To exit Low Power mode, press any key on the operation panel.

The machine returns to the ready condition in about 22 seconds. To change the low Power delay, see page 108.

Specification

Low Power Mode (Economy Mode)	Power consumption	15 W
	Default delay	15 min.
	Recovery time	22 sec.

Recycled paper

Please contact your sales or service representative for recommended recycled paper types that may be used in this machine.

Contents

Safety Information	i
Energy Star program	iv
Part Names	x
Operation Panel	xii

1. SETTING UP

Package Contents	1
Location	1
Installing the Starter Toner Cassette	2
Installing Other Hardware	4
Unlocking the Scanner	4
Removing the Protective Sheet	4
Installing the Document Output Tray	5
Installing the Upper Paper Tray	6
Preparing the Output Tray	6
Connecting to a Computer	7
Connecting the Telephone Line and Optional Telephone Handset	8
Turning On the Machine	9

2. GETTING ACQUAINTED

Paper and Other Media	10
Loading Paper	11
Loading Plain Paper into the Upper Paper Tray	11
Loading Small Size Paper	13
Loading Other Media	15
Loading Envelopes	15
Loading Transparencies	15
Loading Label Paper	15
Second (Additional) Printer	16
Connecting to a Second Printer	16
Paper Feed Unit (Option)	17
Paper Feed Unit Part Names	17
Installing the Paper Feed Unit	17
Loading Paper into the Paper Feed Unit	19
Changing the Paper Size	20

Specifying the Paper Size	20
Installing the Paper Size Indicator	21
Selecting the Paper Source	22
Upgrading Memory	23

3. PRINTING AND SCANNING

Setting up	25
Installing the Software Drivers	25
Features You Can Access From the Printer Driver	27
Using the Second Printer (Additional Printer)	28
Printing to the Second Printer	28

4. FAXING

Switching between Fax Operation and Copy Operation Mode	29
Entering Characters on the Operation Panel	30
Entering Numbers	30
Entering Letters, Symbols and Spaces	30
Deleting Characters and Moving the Cursor	31
Setting up	32
Please Read This First	32
Connecting to the Telephone Line	32
Storing your Own Name/TTI	33
Setting the Dial Mode	34
Storing your Own Fax Number	36
Setting the Date and Time	38
Turning Summer Time (Daylight Saving Time) on/off	39
Sending Faxes	40
How to Send a Fax	40
Entering Pauses and Tones in Fax Numbers	43
Entering Pauses	43
Entering Tones	44
Redialling a Number	44
Automatic Redial	45
Cancelling Automatic Redial	45
Canceling Transmission of a Fax	45
Receiving Faxes	46

Choosing a Reception Mode	46
FAX Model	46
TEL Model	46
Switching between FAX Mode and TEL Mode	47
Receiving calls in TEL Mode	47
Screening out Unwanted Faxes with Authorized Reception	48
Turning Authorized Reception on/off	49
Cancelling Reception of a Fax	49
Making Telephone Calls	50
Faxing During a Telephone Call	50
Sending a Fax During a Telephone call	51
Receiving a Fax During a Telephone call	51
Monitoring the Line while Dialing with On Hook	52
Remote Change	52
Storing Fax and Telephone Numbers	54
Quick Dials	54
Storing Quick Dials	55
Editing Quick Dials	56
Clearing Quick Dials	55
Name Dials	59
Storing Name Dials	59
Deleting Name Dials	61
Dialing with Name Dials	62
Reports and Lists	63
Printing the Journal	63
Printing the Dial List	64
Transmission Result Report	64
Error Report	65
Power Failure Report	65
Unauthorized Call Report	65
Advanced Features	66
Making Machine Sounds Louder or Quieter	66
Sending Faxes Over Unreliable Lines-Slow (4800bps)	67
RDS	68
Page Header	68
Changing On/Off Settings	68

5. COPYING

Making a Copy	70
Making Multiple Copies	71
Making a Book Copy	72
Reduction and Enlargement	73
To Set the Reduction Factor	73
To Set the Enlargement Factor	74
Zoom (In 1% Increments)	75
To Use Zoom	75
Adjusting the Copy Image	76
To Select the Resolution/Photo Setting	76
To Adjust the Image Density	77
Setting an Original on the ADF	78
Sorting Output	80
Sorting Copying	80

6. TROUBLESHOOTING

General	82
Printing and Copying	82
Printing	83
Copying and Faxing	84
Scanning	86
Error Messages	86
When the Receive File Indicator is Lit	90
Clearing a Paper Misfeed	91
Clearing a Feed in the Main Unit	91
Clearing a Misfeed in the ADF	93
Clearing a Misfeed in the Optional Paper Feed Unit	93
When Paper Will Not Feed	94

7. USER MAINTENANCE

Daily Maintenance	96
Replacing the Toner Cassette and the Cleaning Pad	97
Storage	100
Paper	100
Toner Cassette	100

8. TECHNICAL REFERENCE

- Printing the Help List 101
- Customising Default Settings with the User Parameters 102
 - Changing the User Parameters 102
 - User Parameter Switch Summary 103
- Function List 106
- Selecting the Language 107
- Economy Mode 108
 - Changing the Economy Mode 108

9. SPECIFICATIONS 109

- Index 112**

Part Names

Automatic Document Feeder (ADF)

Holds up to 10 sheets of paper for automatic feeding. Place originals face down.

Document guides

Slide the left guide to fit the size of the paper you are feeding.

Exposure glass

Place originals on this glass face down.

Operation panel

Key panel for controlling the machine.

Output tray extension

Pull out to support paper output from the machine.

Top release lever

Pull to release the top unit and open it.

Upper paper tray

Holds up to 100 sheets of plain paper.

Original guide

Guides the original correctly into the machine. Make sure your original fits under this guide.

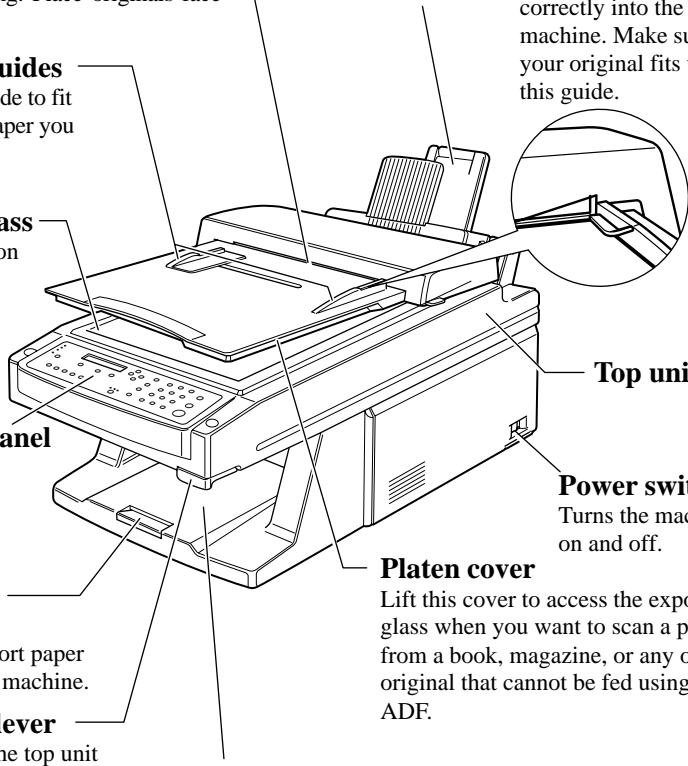

Output tray

Prints are delivered here. This tray can hold up to 50 sheets.

Scanner lock

Locks the scanner to prevent damage during transport. Be sure to release this lock before using the machine.

Upper tray extension

Extend to support originals.

Small size paper feed access panel

This panel can be lowered to provide easier handling when printing on or copying to small size paper.

Power socket

Document output tray

Scanned documents are delivered here.

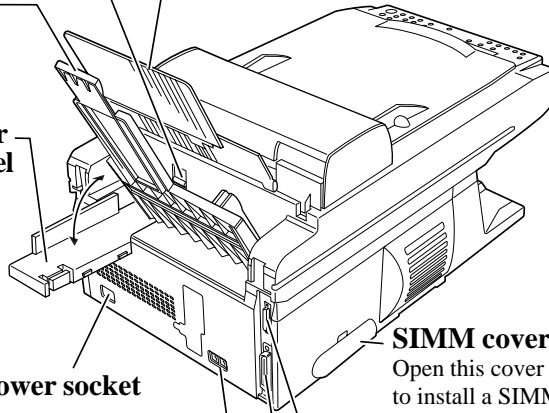

SIMM cover

Open this cover when you want to install a SIMM and expand memory.

Second Printer (Additional Printer) port

You can connect a second printer to this port.

Computer port

Connect your computer here.

TEL/LINE

Connect your telephone line and optional handset here.

Operation Panel

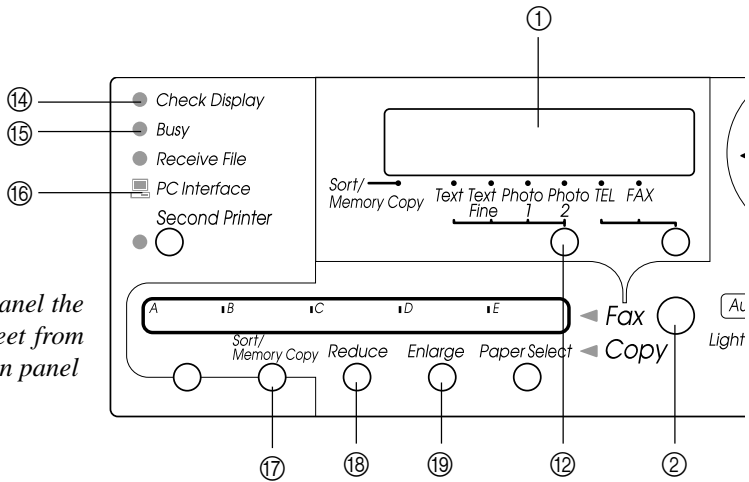

Note

Be sure to panel the protective sheet from the operation panel

<General>

① Display

Messages and prompts appear here.

② Fax/Copy key

Press to switch between fax operation mode and copy operation mode. The indicators to the left of this key show which mode the machine is currently in.

③ Numeric keypad

Use these keys to enter the number of copies, dial a fax number or specify values.

④ Clear key

Press to delete the character to the left of the display cursor. When the cursor is located at the far left position, pressing this key deletes all of the input characters (when programming functions only).

⑤ Start key

Press to start copying or begin sending or receiving a fax.

⑥ Stop key

Press this key to interrupt the current operation and return the machine to the standby state. To reset printer mode, hold down this key for at least 3 seconds.

⑦ Economy Mode/Clear Modes key

Pressing this key clears any selected settings to their defaults and cancels the ongoing operation. Hold down this key for more than about 3 seconds to turn Economy mode on or off.

☛ *Economy Mode, see page 108.*

⑧ Economy Mode indicator

Lights when Economy mode is turned on.

⑨ Help/Function key

Use to print the Help List. Press once and enter a number for access to various function settings.

☛ *Printing the Help List, see page 101.*

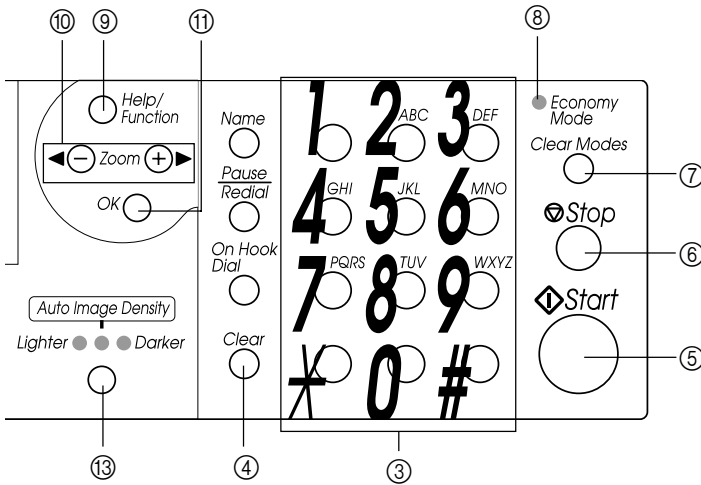

10 Zoom keys

In copy mode, press these keys to fine-tune the preset reduction and enlargement ratios. Also use to select function settings and navigate the function menus.

11 OK key

Press to enter values or execute an operation when prompted by a message on the display.

12 Original Type Select key

Press to select a setting that best matches your copy original or fax document.

☛ *Image Type, see page 76.*

13 Density key

Press to make copies/faxes lighter or darker. Select Auto Image Density to let the machine choose a suitable setting.

14 Check Display indicator

Blinks to alert you to read a message on the display.

15 Busy indicator

Lights during a fax operation and when making telephone calls.

16 PC Interface indicator

Lights while the machine is receiving data from a connected computer.

<Copying>

17 Sort/Memory Copy key

Press to change order in which your copy sets are delivered.

☛ *Sorting Output, see page 80.*

18 Reduce key

Press to reduce the size of an image when copying.

☛ *To Set the Enlargement Factor, see page 73.*

19 Enlarge key

Press to enlarge the size of an image when copying.

☛ *To Set the Reduction Factor, see page 74.*

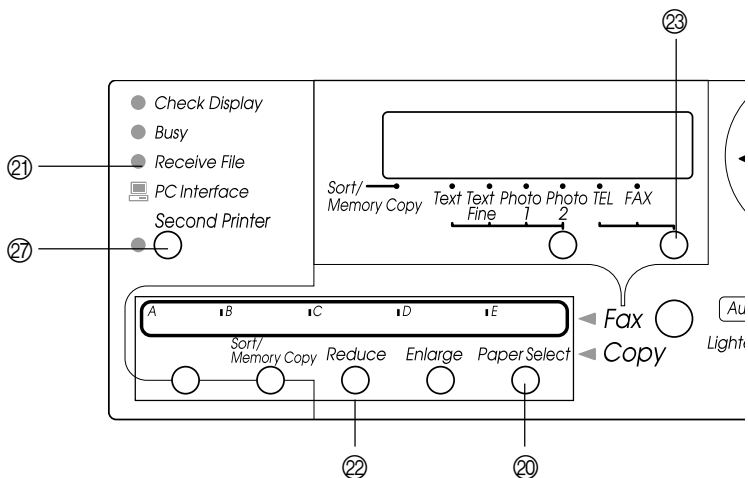

20 Paper Select key

Press to select the copy paper size. When the optional paper feed unit is installed, press to switch between paper sources.

<Faxing>

21 Receive File indicator

Lights to let you know there is received fax data in memory that could not be printed for some reason.

☛ *Substitute Reception, page 46.*

22 Quick Dial keys

In fax operation mode, press one of these keys once to recall a fax or telephone number you have stored beforehand. In copy operation mode, these keys have different uses.

☛ *Quick Dials, see page 54.*

23 Reception Mode key

Press to choose whether the machine should answer all calls automatically.

☛ *Choosing the Reception Mode, see page 46.*

24 Name key

Press to recall a fax or telephone number stored in a Name Dial.

☛ *Name Dials, see page 59.*

25 Pause/Redial key

Press this key in fax standby mode to recall the last number dialed.

While entering a fax number, press this key to enter a pause (shown on the display as a hyphen).

26 On Hook Dial key

Press this key to establish a connection with the telephone line connected to the machine for dialing.

☛ *On Hook, see page 52.*

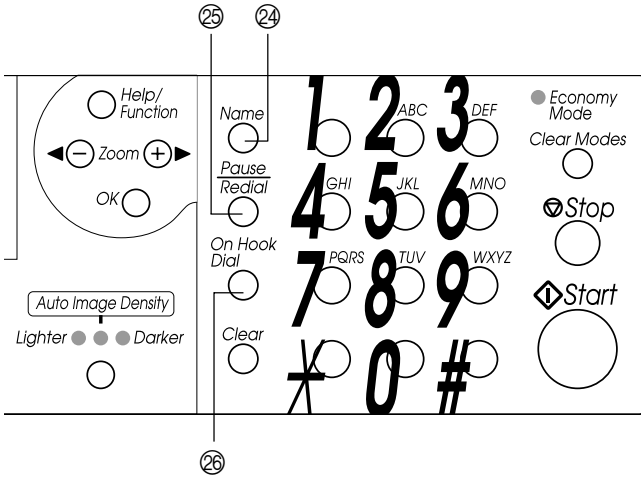

<Printing>

27 Second Printer key

Press this key to select between printing to this machine (indicator off), and printing to a second printer connected to the machine (indicator on).

This page is intentionally blank

1. SETTING UP

Package Contents

Make sure that all of the items shown in the Package Contents sheet that comes with the machine are included.

⚠ WARNING	
❗	Make sure the wall outlet is near the machine and freely accessible so that in event of an emergency it can be unplugged easily.
⊘	Do not put any metal objects or containers holding water (e.g. vases, flowerpots, glasses) on the machine. If the contents fall inside the machine, a fire or electric shock could occur.
⚠ CAUTION	
⊘	Keep the machine away from humidity and dust. A fire or an electric shock might occur.
⊘	Do not place the machine on an unstable or tilted surface. If it topples over, it could cause injury.
❗	If you use the machine in a confined space, make sure there is a continuous air turnover.

Location

Environment

	Acceptable	Recommended
Temperature	10 to 35°C (50 to 95°F)	15 to 25°C (59 to 77°F)
Humidity	15 to 80%	30 to 70%

- The machine must be level within 3mm (0.11") both front to rear and left to right.

Locations to Avoid

- Areas exposed to direct sunlight or strong light (more than 2000 lux).
- Areas exposed to cool or heated air (from air conditioners, heaters etc.). Sudden temperature changes can cause condensation to form inside the machine.
- Areas where the machine might be subjected to frequent strong vibration.
- Areas higher than 2500m (8,221 feet) above sea level.

Machine Clearance

Place the machine near the wall outlet, providing minimum clearance as shown.

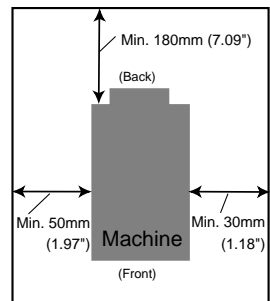

Installing the Starter Toner Cassette

- 1 Pull the top release lever (①) and open the top unit (②).**

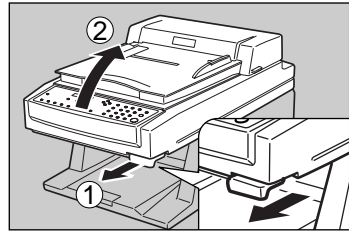

- 2 Hold the starter toner cassette by its handle, and remove it from its vinyl bag.**

⚠ CAUTION

Keep all plastic bags out of the reach of children.

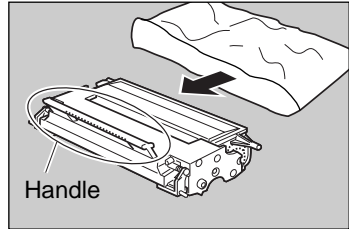

⚠ Important!

Be sure to hold the starter toner cassette by its handle.

📌 Note

Keep the vinyl bag for later repackaging when necessary.

- 3 Holding the starter toner cassette by its handle, gently shake it side to side 5 or 6 times to evenly distribute the toner inside.**

⚠ Important!

Be sure to hold the starter toner cassette by its handle.

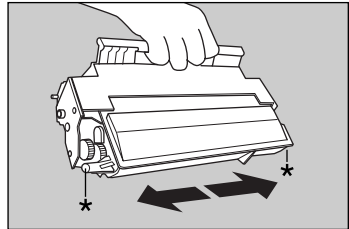

- 4 Look inside the machine and note the locations of the arrows that indicate the toner cassette guides on either side.**

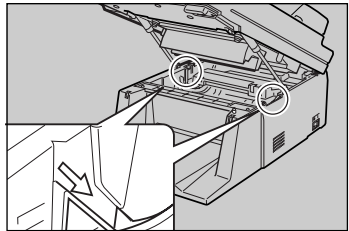

- 5** Make sure the plastic pins (marked with “*” in the illustration next to step 3) on either side of the starter toner cassette slide along the guides inside the machine.

 **Note**

Be sure to hold the starter toner cassette by its handle.

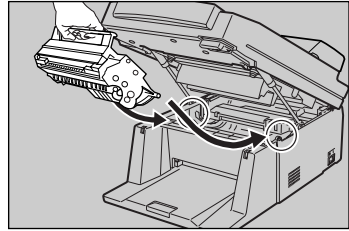

- 6** To close the top unit, press down firmly but gently on both sides of it until the top unit closes and clicks securely into place.

 **Note**

Background gray cast is sometimes evident just after installing a new toner cassette.

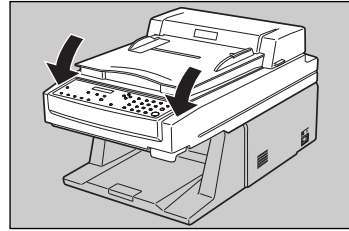

Installing Other Hardware

Unlocking the Scanner

Important

Be sure to unlock the scanner before using the machine.

The machine will not operate correctly if the scanner is locked.

- 1** Unlock the scanner by pulling the lever located at the back of the machine.

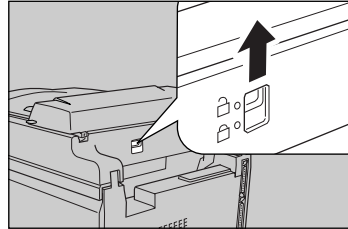

Removing the Protective Sheet

- 1** Open the ADF cover (①) and then remove the protective sheet (②).

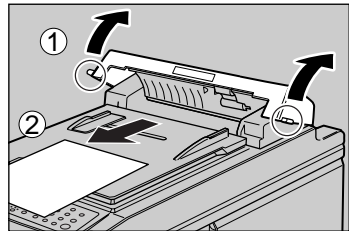

- 2** Close the ADF cover and make sure it locks securely into place.

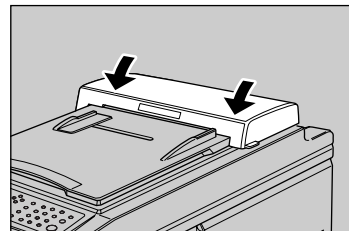

Installing the Document Output Tray

- 1** Look at the rear of the machine to confirm where the document output tray should fit.

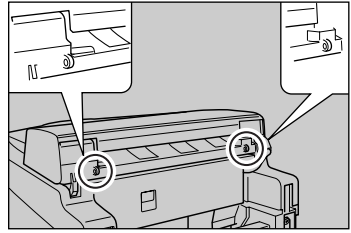

- 2** Insert one end of the document output tray into the slot provided. Then gently bend the tray so the other end fits into the second slot.

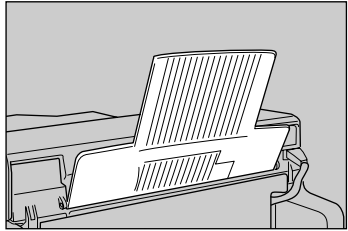

- 3** Make sure the small pieces of plastic film curl upwards as shown.

Important!

Documents will not be delivered properly unless the pieces of film are set as shown.

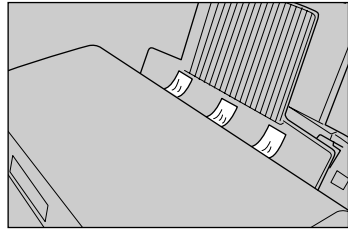

Installing the Upper Paper Tray

- 1** Look at the rear of the machine and note the locations of the slots for insertion of the upper paper tray on both sides.

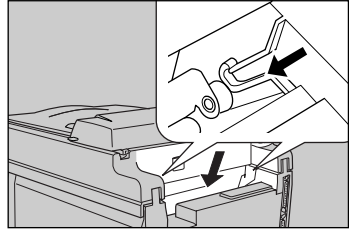

- 2** To install the upper paper tray, press down on both sides of the tray, making sure that it is inserted as far as it will go.



Note

Paper will not be fed correctly into the machine if the upper paper tray is not inserted all the way in.

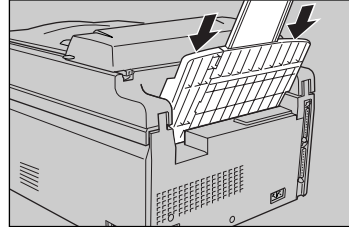

Preparing the Output Tray

- 1** Pull out the output tray extension as shown.

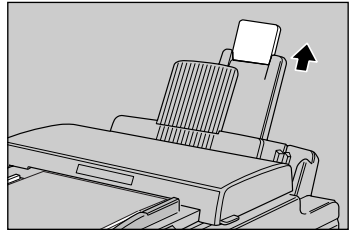

Connecting to a Computer

Important!

Make sure that the power of both the machine and your computer is turned off before making the connection.

- 1** Plug one end of the provided parallel cable into the lower port on the side of the machine, and secure it in place as shown in the illustration.

Note

- *The machine must be connected to a computer for printing.*
- *Use the cable that comes with the machine to connect to your computer.*

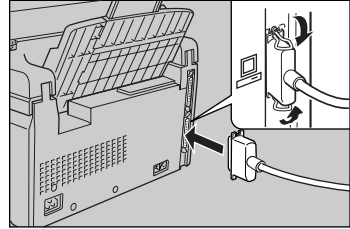

- 2** Connect the other end of the parallel cable to your computer's parallel printer port.

Connecting the Telephone Line and Optional Telephone Handset

There are two similar sockets located at the rear of the machine.

- LINE – the telephone line connection
- TEL – for an optional handset when sharing the line with a telephone

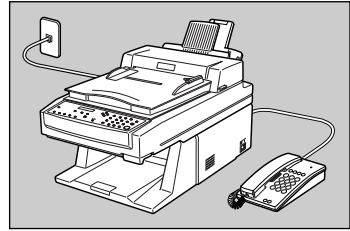

1 Plug the line cable into the LINE socket at the rear of the machine.

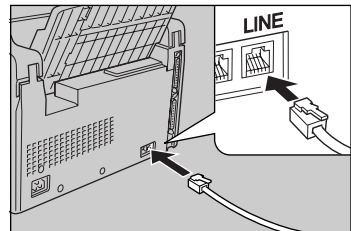

2 Connect the other end of the line cable to your telephone line wall socket.

If you have the optional telephone handset, now do the following:

3 Plug the telephone handset cable into the TEL socket at the rear of the machine.

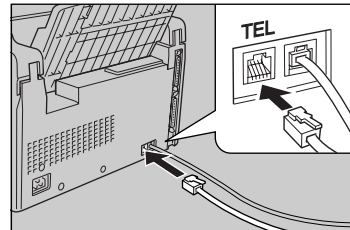

4 Connect the other end of the telephone handset cable to your telephone.

 **Note**

If you wish to also be able to receive incoming telephone calls, you must set the Reception mode to Telephone.

 Choosing a Reception Mode, see page 18

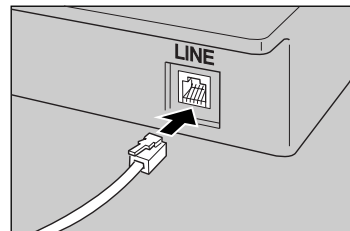

Turning On the Machine

⚠ WARNING

- Only connect the machine to the power source described on the inside of the front cover.
- Avoid multi-wiring.
- Do not damage, break or make any modifications to the power cable. Do not place heavy objects on it, pull it hard or bend it more than necessary. These actions could cause an electric shock or fire.
- Do not plug or unplug the power cord with your hands wet. Otherwise, an electric shock might occur.

⚡ Important!

Whenever you turn on the machine, make sure that no paper is loaded beforehand.

- 1 Attach the power cable to the machine and plug the other end into an outlet.**

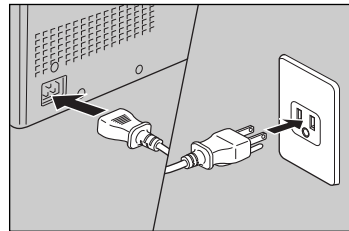

- 2 Turn on the machine.**

📌 Note

You can select your preferred language used on the operation panel and on reports.

➡ Selecting the Language, see page 107.

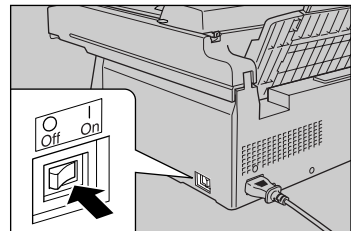

2. GETTING ACQUAINTED



Important!

☞ *The default display language is English. For how to change to your preferred language, see page 107*

Paper and Other Media

The machine supports printing on the following types of paper/media from the upper paper tray.

Refer to the following pages for details.

Paper/Media type (Paper size)		Display	Page
Plain paper	Letter (8 ¹ / ₂ " × 11")	Letter (8 ¹ / ₂ × 11)	p.11
	Half Letter	5 ¹ / ₂ × 8 ¹ / ₂	p.11
	Legal (8 ¹ / ₂ " × 14")	Legal (8 ¹ / ₂ × 14)	p.11
	A4 (210mm × 297mm)	A4	p.11
	A5 (148mm × 210mm)	A5	p.11
	F4 (8 ¹ / ₄ " × 13")	8 ¹ / ₄ × 13	p.11
Envelopes	Executive	Exec (7 ¹ / ₄ × 10 ¹ / ₂)	p.13, 15
	COM 10	Com 10 (4 ¹ / ₈ × 9 ¹ / ₂)	p.13, 15
	Monarch	Mon. (3 ⁷ / ₈ × 7 ¹ / ₂)	p.13, 15
Transparencies			p.15
Label paper			p.15



Note

Do not attempt to use the following types of paper: wrinkled or creased paper, curled or rolled paper, paper containing carbon, carbon-backed paper, coated paper, onion skin or other very thin paper.



CAUTION



Do not reuse stapled paper. Do not use aluminium foil, paper containing carbon or other conductive paper. Otherwise, a fire might occur.

Loading Paper

After you have set up the machine you need to load paper then specify the paper size using the procedure below.

Important!

When loading paper into the upper paper tray, do not load more than 100 sheets of plain paper (80 g/m² or 20 lb). Overloading the upper paper tray can cause misfeeds.

Loading Plain Paper into the Upper Paper Tray

- 1** Fan the stack of paper to make sure that all pages are free and are not sticking together. The upper paper tray holds up to 100 sheets of plain paper (80 g/m² or 20 lb).

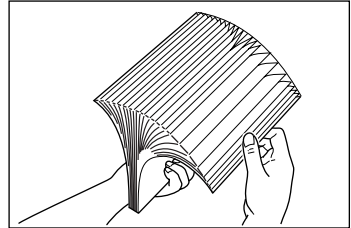

- 2** Straighten up all four sides of the stack by tapping them on a desk or tabletop.

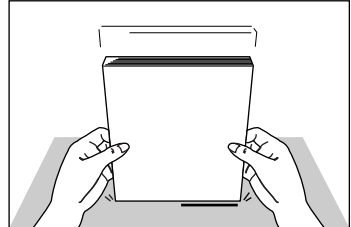

- 3** Set paper into the upper paper tray. Make sure that the top of the stack is not higher than the limit mark on the tray guide.

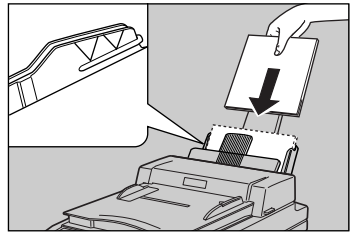

- 4** Squeeze the tray guide and slide it against the edge of the stack.

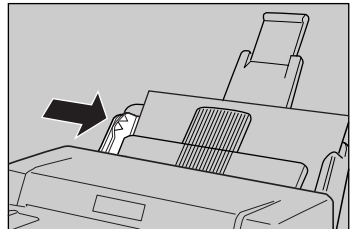

5 Press  *Help/Function*.

Prt Help List ▶

6 Press *Zoom*  ▶.

Function no.: __

7 Press  ^{MNO} .



61 Tray Pap.Size

 **Note**

If the paper feed unit (option) is installed, refer to page 19 for details on how to specify the paper size.

8 Press *OK* .

Tray guide OK? ^{OK}

9 Press *OK* . Then press *Zoom*  ▶ or  *Zoom* until the correct paper size appears.

Letter(8¹/₂ × 11)? ▶

10 When the correct paper size is on the display, press *OK* . If the paper feed unit (option) (page 17) is installed, you can also select its paper size at this time.

Registered



 **Note**

Do not carry out any operations while “Registered” appears on the display.

6 Others ^{OK}

11 Press  *Help/Function* to return to the standby display.

 **Tip**

If the paper feed unit (option) is not installed and the machine is in copy operation mode, you can press *PaperSelect*  in place of  *Help/Function* in step **5**. Next, skip step **6** and **7**, and jump directly to step **8**.

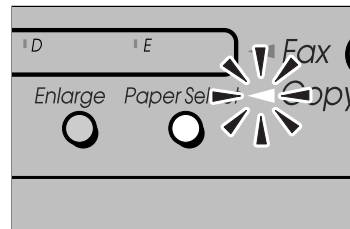

Loading Small Size Paper

Note

We recommend that you always feed small size paper vertically with the shorter edge feeding into the machine first.

- 1** Remove all paper before loading small size paper in the upper paper tray.

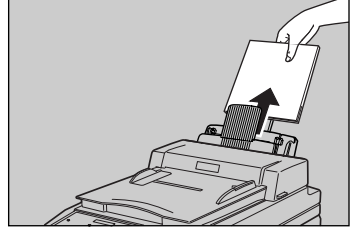

- 2** Open the small size paper feed access panel on the back of the machine by unlatching it as shown in the illustration. Opening the small panel makes it easy to handle small size paper.

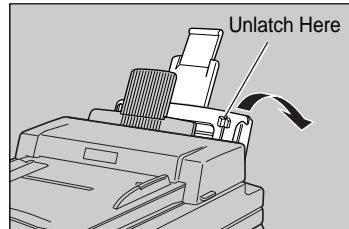

- 3** Set paper into the upper paper tray. Make sure that the top of the stack is not higher than the limit mark on the tray guide.

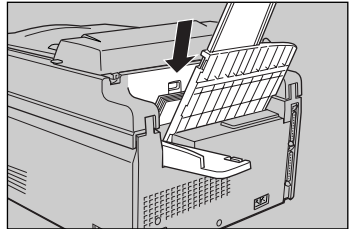

- 4** After setting the paper into the tray, raise the small panel until it snaps securely into place.

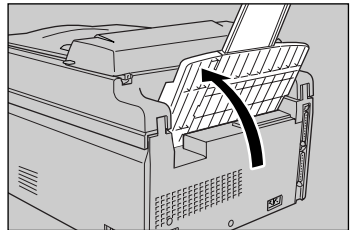

5 Press  *Help/Function**

Prt Help List ▶

6 Press Zoom  ▶.

Function no.: __

7 Press   .



61 Tray Pap.Size

 **Note**

If the paper feed unit (option) is installed, refer to page 19 for details on how to specify the paper size.

8 Press OK .

Tray guide OK? 

9 Press OK . Then press Zoom  ▶ or  ◀ Zoom until the correct paper size appears.

5¹/₂ × 8¹/₂? ▶

10 When the correct paper size is on the display, press OK .

Registered



 **Note**

Do not carry out any operations while “Registered” appears on the display.

6 Others 

11 Press  *Help/Function* to return to the standby display.

 **Tip**

If the paper feed unit (option) is not installed and the machine is in copy operation mode, you can press  in place of  in step **5** . Next, skip step **6** and **7**, and jump directly to step **8** .

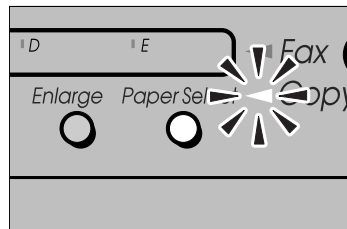

 **Important!**

Be sure to specify the paper size again before copying, printing or receiving faxes onto A4 or Letter size paper. If you do not, you will not be able to receive faxes.

Loading Other Media

Use the following procedures to load envelopes, transparencies, and label paper.

Loading Envelopes

Load up to 5 envelopes at a time using the same procedure for loading small size paper on page 13.

- *Insert envelopes print side up with the stamp position as shown.*

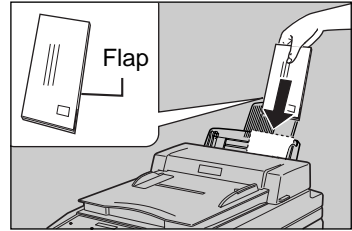

- *Envelope flaps should be securely folded down, so the envelope is “closed”. This is especially important when printing on envelopes with adhesive on the flaps because heat generated during the printing process can cause the adhesive to melt and get on rollers.*

Note

 Paper select operation, see page 14.

Loading Transparencies

Load only one transparency at a time using the plain paper loading procedure on page 10 for large transparencies, and the small paper loading procedure on page 12 for small transparencies.

Note

 Refer to the paper select operation on page 12 for large transparencies or page 14 for small ones.

Loading Label Paper

Load only 10 sheets of label paper at a time using the plain paper loading procedure on page 10.

Note

 Paper select operation, see page 12.

Second (Additional) Printer

This machine features a port for connecting a second printer. When connected, press the *Second Printer* key to switch between the two printers.

 **Note**

Make sure that the power of your computer is turned off before making the connection.

Connecting to a Second Printer

- 1 Turn off both the machine and your second printer.**

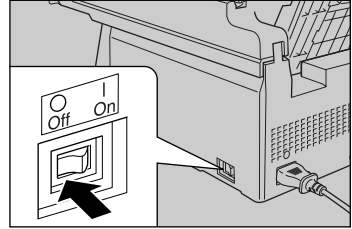

- 2 Connect one end of a parallel interface cable to your second printer.**

- 3 Connect the other end of the cable to the second printer port, securing it in place with the screws.**

 **Note**

- Only use a standard IEEE 1284 compliant 36-pin parallel cable.
- Using the second printer, see page 28.

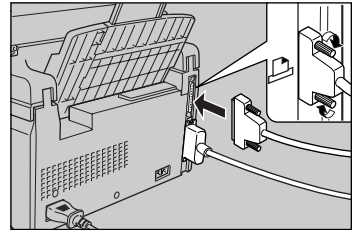

Paper Feed Unit (Option)

This section describes how to install the paper feed unit (option) and how to load paper in it. Addition of a paper feed unit provides you with a second paper source that holds up to 250 sheets of A4 or Letter size paper.

Important!

Make sure that machine power is turned off and that the power cord is unplugged from the power socket before installing the paper feed unit.

Paper Feed Unit Part Names

- ① Front guide
- ② Side guide
- ③ Limit mark
- ④ Paper size indicator
- ⑤ Connector
- ⑥ Corner guides
- ⑦ Metal plate

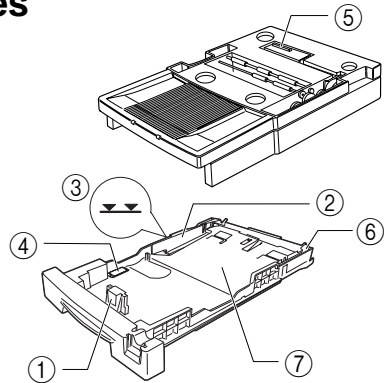

Installing the Paper Feed Unit

- 1** Remove all the packing tapes from the paper feed unit and pull the paper tray out of the unit.

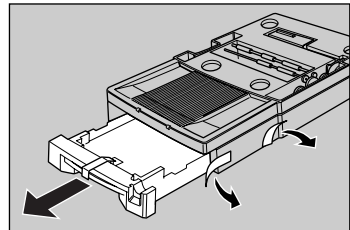

- 2** After removing all tapes and cardboard from inside of the paper tray, insert the tray back into the machine until it locks into place. Locate the paper feed unit where you plan to use the machine.

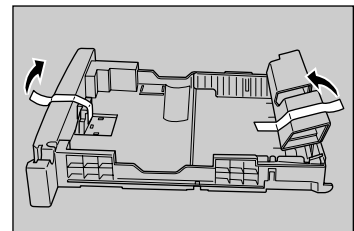

Note

Be sure to place the paper feed unit on a level surface.

3 The machine has handholds at the locations shown in the illustration. Note that the illustration shows the machine as viewed from above.

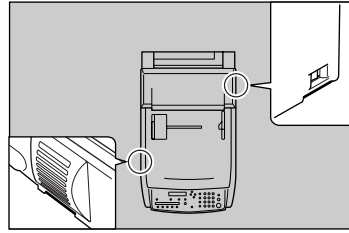

- This illustration shows the handhold location on the right side of the machine.

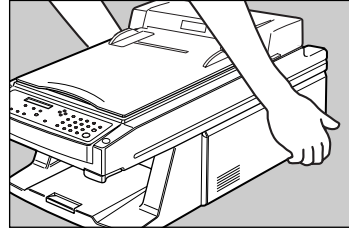

- This is the handhold location on the left side of the machine.

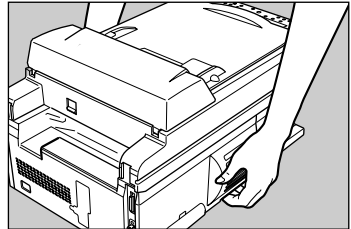

4 Carefully lower the machine onto the paper feed unit, making sure that the dowels on the paper feed unit fit into holes in the bottom of the machine properly.

⚠ CAUTION
 When lifting the machine, make sure your hands are at the locations indicated by “*” in the illustration. This protects against pinching your fingers between the machine and paper feed unit.

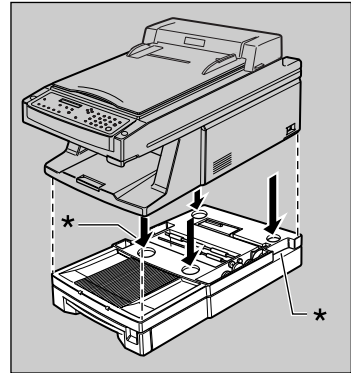

Note

After the above installation, attach the power cord to the machine and plug the other end into an outlet. Refer to page 8 for details.

Loading Paper into the Paper Feed Unit

You can load either A4 or Letter size paper into the paper feed unit. Refer to page 20 for details on how to change the positions of the paper guides inside of the tray to match the type of paper you are using.

- 1** Pull out the paper tray and remove it from the paper feed unit.

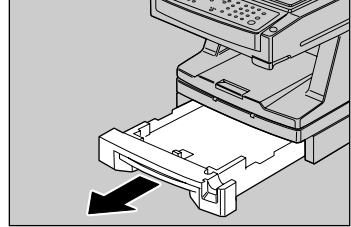

- 2** Press down on the metal plate in the bottom of the paper tray until the plate locks into place with a “click”.

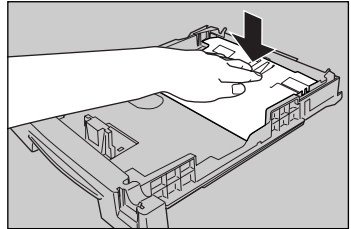

- 3** Up to 250 sheets of plain paper (80 g/m² or 20 lb) can be inserted into the paper tray as shown in the illustration. Make sure that the top of the stack is not higher than the limit mark on the side fence.

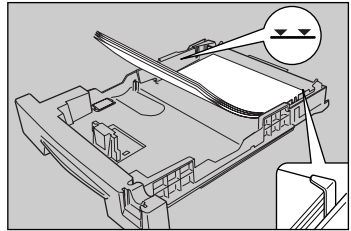

Note

Make sure the leading corners of the paper fit under the corner guides.

- 4** Slide the paper tray back into the paper feed unit until it locks into place.

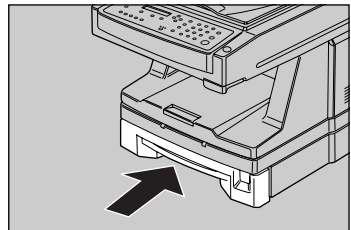

Changing the Paper Size

Use the following procedure to set the positions of the paper guides inside the paper tray for either A4 or Letter paper.

- 1** Squeezing in on both sides of the front guide, slide it to the correct position for the desired paper size.

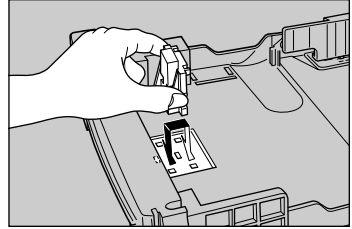

- 2** Squeezing in on both sides of the side guide, slide it to the correct position for the desired paper size.

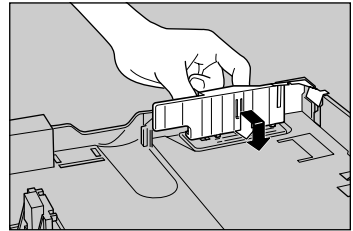

Important!

Whenever you change the paper size, be sure to also specify the paper size using the procedure below.

Specifying the Paper Size

After you install the paper feed unit (option), you can select between the upper paper tray and the paper feed unit as the paper source, and specify the size of paper in the paper feed unit.

- 1** Press  *Help/Function**

Prt Help List ▶

- 2** Press *Zoom*  ▶.



Function no.: __

- 3** Press   .



61 Tray Pap.Size

4 Press **OK** .

 **Note**

The actual message that appears on the machine's display depends on the paper source you last used. If "Upper Tray?" appears, press Zoom  or  Zoom to display the "Lower Tray?" message before proceeding with step **4**.

Lower Tray? 

5 Press **OK** . Then press Zoom  or  Zoom until the correct paper size appears.

Letter(8¹/₂ × 11)? 

6 When the correct size is on the display, press **OK** .

 **Note**

Do not carry out any operations while "Registered" appears on the display.

Registered

6 Others 

7 Press  ^{Help/}Function to return to the standby display.

Installing the Paper Size Indicator

1 Remove the paper size indicator (①). Positioning the indicator so the side that shows the paper size you are using (A4 or Letter) is facing outwards, insert it into the front of the paper tray (②).

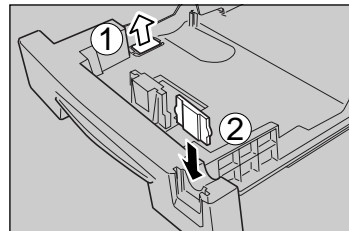

Selecting the Paper Source

1 Press ^{Paper Select}  until the desired paper source appears.

The upper paper tray is selected when "U" is on the display, and the paper feed unit is selected when "L" is on the display.

☞ Loading plain paper into the upper paper tray, see page 11.

100%

U 01

100%

L 01

Upgrading Memory

You can install a Single Inline Memory Module (SIMM) to upgrade the on-board memory of the machine.

The machine is shipped from the factory with a 4MB SIMM which can be replaced with an 8MB, 16MB or 32MB SIMM.

Use the following procedure to install an 8MB, 16MB or 32MB SIMM.

Note

The following are the required specifications for a SIMM used with this machine: 72-pin, 60ns, Extend Date Out (EDO), parity/non-parity.

Important!

Make sure you touch some grounded metal object with your hand to discharge any electrostatic charge from your body before handling the SIMM.

1 Turn off the machine.

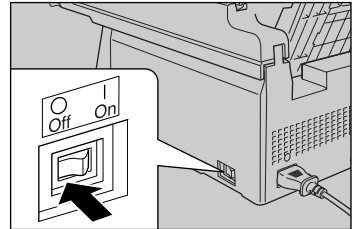

2 Remove the SIMM cover located on the left side of the machine.

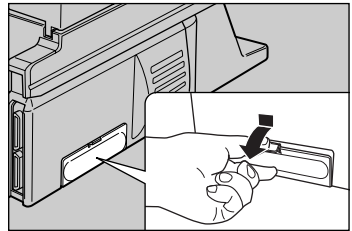

3 Pull apart the hooks on the both sides of the SIMM board that hold it in place.

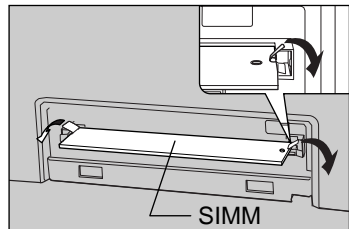

4 Carefully lift out the currently installed SIMM board.

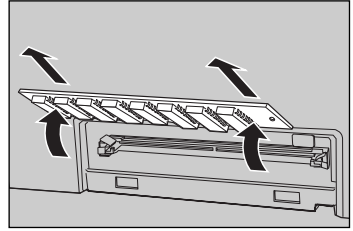

5 Angle the new SIMM board as shown in the illustration, and insert it down into the slot. Gently rock it back and forth until you hear it snap into place.

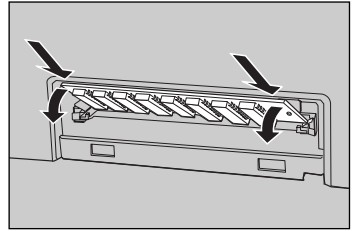

Important!

Make sure the SIMM board is oriented correctly when you insert it into the slot.

6 Make sure the hooks on the sides of the SIMM board snap securely into place.

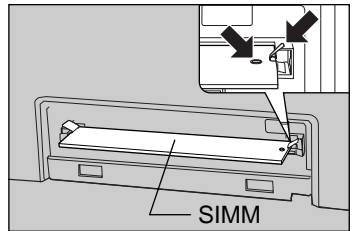

7 Replace the cover by inserting its tabs into the holes provided, as shown in the illustration.

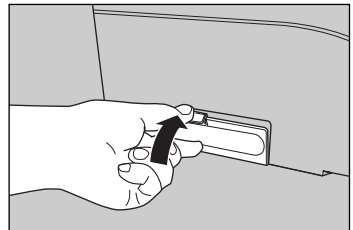

3. PRINTING AND SCANNING

When connected to a compatible PC, you can use this machine as a high performance laser printer and black and white scanner.



Important!

- *Make sure that your PC parallel port is set to ECP. If it is not, please consult your PC manual on how to change it.*



Note

- *For information on PC hardware and software requirements, please read the README file on the CD.*
- *Printer drivers are provided for both Windows® 95/98 and Windows® 3.1, but the scanning feature requires Windows® 95/98.*

Setting up

Before you can start printing and scanning you need to do the following if you have not done so already:

- Connect the machine to your PC
- Install the software drivers on your PC

Installing the Software Drivers

Follow the steps below to install the printer/scanner drivers on your PC.

- 1** Switch the machine on.
- 2** Make sure the machine is connected to your PC and paper is loaded in the upper paper tray.
 - ☞ *Connecting to a computer, see page 7*
 - ☞ *Loading Paper, see page 11*
- 3** Insert the provided software CD into your CD-ROM drive.

4 Do one of the following according to your operating system:**• Windows® 95/98**

Run the setup application. For example, if your CD-ROM is assigned to D, run “D:\Scan-in\Setup.exe”.

• Windows® 3.1

First copy the disk images under the directory named “3.1” on the CD-ROM to floppy disks. Then insert the first floppy disk into your floppy disk drive and run “install.exe”.

 **Note**

You cannot install from CD-ROM under Windows 3.1.

Only the printer driver will be installed under Windows 3.1.

5 Follow the instructions that appear on the display.

For detailed information on how to print and scan from your PC, please refer to the online help provided.

Features You Can Access From the Printer Driver

Printer Driver Contents

■ Paper Defaults

- Paper size : Size, Measurement Unit
- Page orientation : Portrait, Landscape
- Output : Copies, Print in reverse order
- Paper source : Source
- About

■ N-Up Printing

- Select a Layout Option : Normal, Reduce for N-up printing
(Print page borders ; 2 pages up/sheet ; 4 pages up/sheet)

■ Document

Document Type Settings

	Automatic	Photo (Grayscale)	Desktop Publishing	High Speed Draft	Business Graphics
Graphics Mode	Raster	Raster	GI/2	Raster	Raster
Font Resolution (dpi)	600	600	600	300	600
Graphics Resolution	High	High	High	High	High
Halftone	Screening	Screening	Screening	Screening	Dithering

- Job Settings : True Type Mode, Name

■ Configuration

- Device Configuration : Feeder ; Toner Save Mode ; Time-out

■ Fonts

- Font Manager (To add printer fonts)

■ Overlays

- Overlay Assignments : None, All pages, Odd/Even pages, First/Other pages
- Cover/Divider page Overlays
- Create New Overlay
- Manage Overlays : Get files from other sources to use as overlays, Send created overlays to other sources, Rename overlays, Remove overlays

Important!

After printing a large number of pages, wait a few minutes before turning off the machine.

Note

Be sure to use online help and Read me file of the printer driver to get the most out of all the printer features and functions.

Using the Second Printer (Additional Printer)

Use the following procedure to switch between this machine and a second printer when a second printer is connected.

Important!

If the second printer has a bi-directional mode, make sure you turn it off.

Note

Refer to page 16 for details on connecting a second printer.

Printing to the Second Printer

- 1** Press  **The Second Printer indicator lights.**

Important!

Whenever you change printers, be sure to also change to the appropriate printer driver on your computer.

Note

While the Second Printer Indicator is lit, print data from your computer passes through the machine to the second printer.

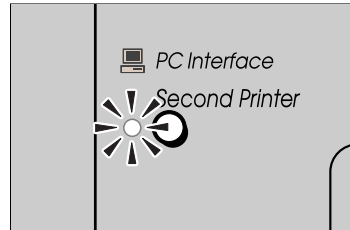

- 2** Perform the required print operation with the application you are using.

4. FAXING

Your machine is furnished with superior faxing capabilities and wide a range of powerful fax features. Here are some of the things you can do:

- Send and receive fax messages
- Store fax numbers you often use and recall them with a single key press
- Redial the previous fax number
- Share your fax line with a telephone
- Keep track of machine usage through printed reports
- Customise default settings to suit your requirements

 **Note**

Please read the Setup section before you start. It explains how to set up the fax feature to suit your needs.

Switching between Fax Operation and Copy Operation Mode

This machine has two modes: fax operation mode and copy operation mode. You can still receive fax messages when the machine is in copy operation mode, but if you wish to send a fax you must make sure the machine is in fax operation mode.

To switch back and forth between copy operation mode and fax operation mode, press  **Fax**  **Copy**.

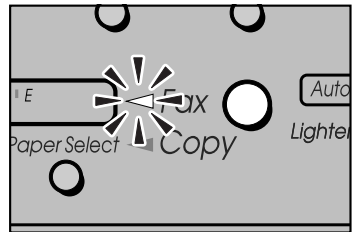

The Fax and Copy indicators indicate which mode the machine is currently in.

 **Note**

When the machine automatically switches to Economy Mode, all indicators turn off. Press any key to exit Economy mode.

- ☛ *Economy Mode, see page 108.*
- ☛ *You can select the default mode the machine starts in. See User Parameters on page 102.*

Entering Characters on the Operation Panel

Entering Numbers

Enter digits when dialing inputting or fax numbers, specifying function codes, or registering various information, such as your own fax number.

To enter digits 0-9, press the appropriate key on the numeric keypad.

E.g. to enter the number 12345678, press 

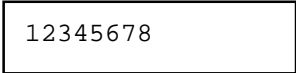













☛ Entering Pauses and Tones in Fax Numbers, see page 43.

Entering Letters, Symbols and Spaces

When the display asks you enter a name, you can use the numeric keypad to enter characters and symbols.

To enter a character, press the appropriate key on the numeric keypad until the character appears. Then press the Zoom  key to move the cursor forward.

Press this key repeatedly	To enter these characters:
	1
	A B C 2 a b c Ä ä
	D E F 3 d e f
	G H I 4 g h i
	J K L 5 j k l
	M N O 6 m n o Ñ Ñ ñ ö
	P Q R S 7 p q r s
	T U V 8 t u v Ü ü
	W X Y Z 9 w x y z
	*
	[Space] . - 0 + ? / : * % & ! () [] ”
	#

Note

Some special characters in lower case appear identical in upper case on the display due to space limitations. These characters are printed correctly on lists and reports.



Deleting Characters and Moving the Cursor

When entering names and storing numbers:

- To delete the character to the left of the cursor, press .

Note

If the cursor is at the far left of the display, pressing  deletes the whole name and number.

- To move the cursor left, press the  Zoom key.
- To move the cursor right, press the Zoom  key.

Setting up

Please Read This First

Before you can send or receive faxes you must connect the machine to a telephone line and store the following settings:

- ☛ *Own Name/TTI, see page 33.*
- ☛ *Dial Mode, see page 34.*
- ☛ *Own Fax Number, see page 36.*
- ☛ *Date and Time, see page 38.*

In addition, you may wish to adjust the following:

- ☛ *Selecting the Language, see page 107.*
- ☛ *Summer Time (Daylight Saving Time), see page 39.*
- ☛ *The volume of sounds the machine makes, see page 66.*

If you wish to share the line with a telephone handset, you may need to change the reception mode.

- ☛ *Choosing a Reception Mode, see page 46.*

Connecting to the Telephone Line

There are two similar sockets located at the rear of the machine.

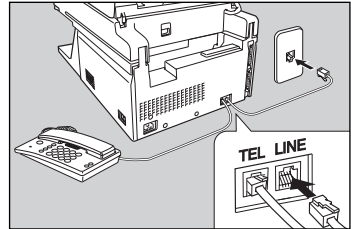

- LINE—the telephone line connection
- TEL—for an optional handset when sharing the line with a telephone

1 Insert the line cable into the LINE socket at the rear of the machine.

2 Connect the other end of the line cable to your telephone line.

Storing your Own Name/TTI

Store your name or name of your organization. When you send a fax, this identification appears at the top of the page when printed at the other end. It is also shown on the other party's display during communication. It can be up to 32 characters long.

☛ *Entering Characters on the Operation Panel, see page xii, 30.*

☛ *If you do not want this identification printed on faxes you send, see Page Header on page 68.*

1 Press *Help/Function*.

Prt Help List ▶

2 Press Zoom .

Function no.: __

3 Press .

16 Own name/TTI^{OK}

4 Press *OK* .

■

5 Enter your name or name of your organization.

E.g. press Zoom

Zoom Zoom

Zoom Zoom

Zoom Zoom

XYZ CO. ■

Note

To clear the entire setting, make sure the cursor is at the far left position then press



Press *OK* to clear the setting, or press



to cancel this operation

XYZ CO.

Delete? ^{OK}

6 Press **OK** . The display opposite will flash briefly on the display and then the function menu will reappear.

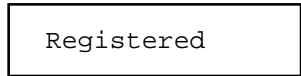

 **Note**

Do not carry out any operations while “Registered” appears on the display.

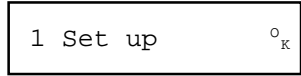

7 Do one of the following:

- Enter another function number.
- Press  to return to standby mode.

Setting the Dial Mode

Specify the type of telephone line you are using (tone or pulse dial). If you are unsure of what this should be, please consult your line provider. If you are outside of North America and the machine is behind a PABX, you should also provide the following details:

- The PABX number that gives you an outside dial tone—this is frequently digit zero (0) or nine (9). You can enter 0, or a value between 01 and 99 (00 is not possible).
- The PSTN access method. This will depend on your locale and the PABX system you are using.

The machine will not function correctly if these settings are not correct. Consult your systems administrator if you are unsure.

1 Press  *Help/Function* .

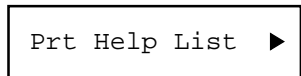

2 Press **Zoom**  .

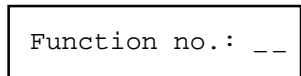

3 Press **1**  **2** .

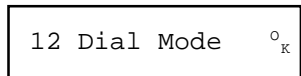

4 Press **OK** .

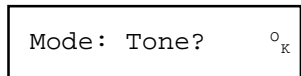

- 5** Press ◀(-) Zoom or Zoom (+)▶ to select **Pulse or Tone.**

Mode: Pulse? _K

- 6** Press OK .

- If your locale is North America, press ^{Help/} _{Function} to finish.

Mode: PABX? No?▶

- 7** If you are outside of North America Press ◀(-) Zoom or Zoom (+)▶ to select whether your fax machine is behind a PABX.

Mode: PABX? Yes _K

- 8** Press OK .

- If you chose “No” in step **7**, proceed to step **12**.
- If you chose “Yes”, proceed to step **9**.

1 Set up _K

Postline by: _

- 9** Enter the digit or digits that give you an outside dial tone on the numeric keypad, e.g. enter 0.

You can enter 0, or a value between 01 and 99 (00 is not possible).



Note

When changing an existing setting, press ^{Clear} to clear it, then enter the new number.



- 10** Press OK .

Method: 0? _K

- 11** Press ◀(-) Zoom or Zoom (+)▶ to select the PSTN access method.

Three methods are available.

<number>: Access the outside line by dialling the number you entered in step **9**

Ground: Ground Start

Flash: Flash Start

Method: Flash? _K

12 Press **OK** . The display opposite will flash briefly on the display and then the function menu will reappear.

 **Note**

Do not carry out any operations while “Registered” appears on the display.

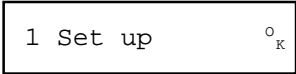
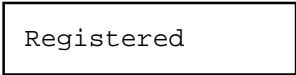

13 Do one of the following:

- Enter another function number.
- Press Help/Function to return to standby mode.



Storing your Own Fax Number

Store the telephone number of the line your machine is connected to. This will appear on the other party’s display during communication and be printed on their and your own reports.

 **Note**

In some locales you cannot store your own fax number.

If the other party is using Authorized Reception or a similar feature to handle messages from certain senders differently, they should specify this information when registering Specified Senders on their machine.

To increase the legibility of your number, you can insert a “+” character and spaces. To enter a “+”, press **#** . To enter a space, press ***** .

 **Note**

The fax number can be up to 20 digits long.

 Entering Numbers, see page 30.

1 Press  **Help/Function**.

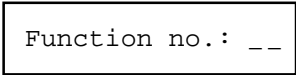
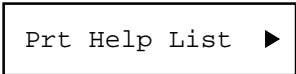

2 Press Zoom .

17 Own Fax No. 

3 Press  .

■

4 Press OK .

+12 3 456■



5 Enter your own fax number on the numeric keypad.

E.g. press #      

Delete? 

 **Note**

To clear the entire setting, make sure the cursor is at the far left position then press . The display opposite will appear.

Press  to clear the setting, or press  to cancel this operation.

Registered

6 Press OK .

 **Note**

Do not carry out any operations while “Registered” appears on the display.



1 Set up 

7 Do one of the following:

- Enter another function number.
- Press Help/Function to return to standby mode.

Setting the Date and Time

This is printed on reports to help you keep track of machine usage.

- If you make a mistake when entering a value, press the  Zoom and Zoom  keys to position the cursor and enter the value again.

1 Press  .

Prt Help List ▶

2 Press Zoom .

Function no.: __

3 Press *bb*.

11 Date/Time

4 Press  then enter the time with the number keys.

Time: 01:13AM °_K

E.g. enter press *0 1 1 3*^{prt} then press  or  to switch between AM and PM.

5 Press .

Year: 99°_K

6 Enter the year on the numeric keypad.

Year: 00°_K

E.g. to enter the year 2000, press *0 0*.

7 Press .

Month: 02°_K

8 Enter the month on the numeric keypad.

Month: 05°_K

E.g. press *0 5*^{prt}.

9 Press **OK** .

Day: 01^o_K

10 Enter the date on the numeric keypad.

E.g. press **2**^{sec}**3**^{sec}.

Day: 23^o_K

11 Press **OK** . The display opposite will flash briefly on the display and then the function menu will reappear.

Registered

 **Note**

Do not carry out any operations while “Registered” appears on the display.

1 Set up ^o_K

12 Do one of the following:

- Enter another function number.
- Press  to return to standby mode.

Turning Summer Time (Daylight Saving Time) on/off

This feature is useful if local custom requires advancing or setting the clock back.

When Summer Time is turned on, the clock is automatically put back or advanced by an hour at the prescribed daylight saving time dates.

☛ For how to switch this feature on or off, see *Changing On/Off Settings* on page 68.

Sending Faxes

How to Send a Fax

This is the basic procedure for sending a fax message. For detailed information and explanations of the advanced features available, see the following pages:

- ☛ *Economy Mode, see page 108.*
- ☛ *Setting Documents For Faxing, see page 40.*
- ☛ *Adjusting Scan Settings, see page 41.*
- ☛ *Quick Dials, see page 54.*
- ☛ *Name Dials, see page 59.*
- ☛ *Redialing a Number, see page 44.*
- ☛ *Entering Pauses and Tones in Fax Numbers, see page 43.*

Set documents you wish to fax in the same way as when setting originals for copying. There are two methods:

- On the exposure glass—set documents face-down one page at a time
 - In the ADF—insert a stack of up to 10 pages face-down
- ☛ *For how to set a document on the exposure glass, see Making a Copy, see page 27*
- ☛ *For the ADF, see Setting an Original on the ADF, see pages 35-36*

1 Check that the standby display is shown.

- If the display is blank, press any key to exit Economy mode.

100%

01

2 If necessary, press to switch to fax operation mode.

Dial/Set orig.

3 Set your document in one of the following ways:

- In the ADF
Carefully insert the document stack face-down into the ADF until the display changes to “Dial number”.
- Make sure this message appears. If it does not, your document will not be scanned from the ADE.
- Lift the platen cover ① then place the first page of your document face-down on the exposure glass aligning it with the arrow mark on the scale ②. Then close the platen cover ③.

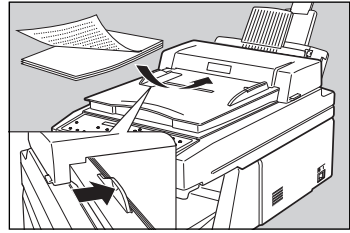

Dial number

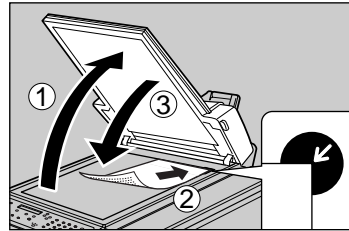

Dial/Set orig.

4 Adjust the scan settings if necessary.

- E.g. if your document is a photograph, press the Original Type Select key twice to select Photo 1.

Setting	Use for:
[Text]	Standard text
[Text Fine]	Detail text
[Photo1]	Photographs
[Photo2]	Mixed text and photographs

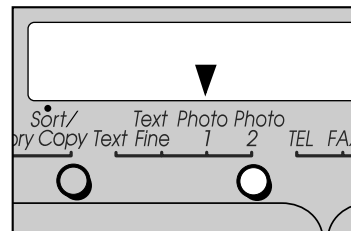

☛ To select the Resolution/Photo setting, see page 76.

5 Dial the fax number in one of the following ways:

- On the numeric keypad.

E.g. press 1¹ 2^{ABC} 3^{DEF} 4^{GHI} 5^{JKL} 6^{MNO} 7^{PQRS} 8^{TUV}.

- Press a Quick Dial key with a number stored in it.

E.g. press <sup>Sort/
Memory Copy</sup>  (GB).

- Press ^{Name}  then enter the first letter of a previously stored Name Dial.

E.g. press ^{Name}  then press 2^{ABC} until the Name Dial you require appears.

12345678_

B: XYZ CO.



ABC CO.



6 Press ^{Start} .

If you set your document in the ADF, the machine dials the fax number and sends your fax message.

If you set your document on the exposure glass in step **7**, you now need to do the following steps:

Dialing...

7 To select the length of your document, press  Zoom or Zoom  until a suitable length appears.



 Vert.: A4? 

8 Press OK  or ^{Start} .

The machine dials the fax number. When the connection is established, if the other party has registered it, their CSI will be displayed. If no CSI is registered, "Transmitting" will appear instead. After the machine has scanned your document, the displays opposite will appear:

Dialing...

9 Do one of the following:

- If all pages of your document have been scanned in, go to step **10**.
- If your document contains more than one page, remove the page from the exposure glass and set the next page before the counter on the display reaches zero. Then press ^{OK}  or ^{Start} . Wait until the displays opposite appear and repeat this step for all pages in your document.

Set next OK?°K08

To finish = # 06

Note

You have 16 seconds to set the next page. If you do not set another page, the machine automatically finishes the transmission.

Set next OK?°K16



To finish = # 14

10 Press # on the numeric keypad to finish sending your fax message.**Entering Pauses and Tones in Fax Numbers**

You can enter pauses and tones when dialing, or store them in Quick Dial and Name Dial numbers.

☛ *Quick Dials, see page 54.*

☛ *Name Dials, see page 59.*

● Entering Pauses

In some situations, you may need to insert a pause in fax numbers. For example:

- If your telephone line is behind a PABX (you have to dial an access code to access outside numbers), insert a pause between the access code and the telephone number.
- For international numbers, enter a pause after the country code.

To enter a pause in a fax number, press ^{Pause}  or ^{Redial} .

The pause is shown on the display as a “-” character.

001-

● Entering Tones

Some organizations offer you special services by telephone which you can access using Touch Tone or DTMF tones.

To enter a tone, press the \star or $\#$ keys.

☛ *Setting the Dial Mode, see page 34.*

Redialling a Number

The machine remembers the last fax or telephone number dialled with the numeric keys, a Quick Dial or a Name Dial. To redial a fax number, follow the procedure below.

Note

- If you dialed the last number with a Quick Dial or Name Dial, the number will be displayed instead of the stored label.
- You cannot redial a number dialled with the handset keypad.

1 Make sure the machine is in fax operation mode.

2 Set your document.

3 Press .

4 Press .

5 Continue the standard procedure for sending a fax.

Automatic Redial

If the machine cannot connect to the other party for some reason (e.g. the line is busy) when sending a document from the ADF, it will wait a while and then attempt to dial again. This will be repeated until the connection is made, or the redial count maximum is reached.

Redial in:1'29"

●Canceling Automatic Redial

To cancel redialing, remove your document from the ADF.

Canceling Transmission of a Fax

To cancel a fax transmission while dialling or during transmission, press the Stop key and remove your document.

Trans. canceled

Note

Once a connection has been established and transmission has begun, you cannot cancel transmission of data already sent.

Receiving Faxes

Choosing a Reception Mode

This machine has two reception modes:

- FAX mode
- TEL mode

●FAX Mode

In this mode the machine automatically answers incoming calls. When a call is received, the machine rings a few times to alert you that a message is being sent, then starts receiving and printing the message.

FAX mode is ideal for a dedicated fax line.

 **Note**

The machine cannot switch between FAX mode and TEL mode automatically.

●TEL Mode

In this mode, the machine does not answer incoming calls automatically. The machine will continue ringing until you pick up the handset (option), or start fax reception manually.

This mode is useful if you are sharing the line with a telephone. If the caller is a person, you can answer the telephone normally, but if it is a fax machine you can still receive the message.

 **Note**

This mode requires someone to be near the machine to receive fax messages. If nobody answers the call, fax messages will not be received.

☞ *Receiving Calls in TEL Mode, see page 47.*

● Switching between FAX Mode and TEL Mode

Press the Reception Mode key to switch between FAX mode and TEL mode.

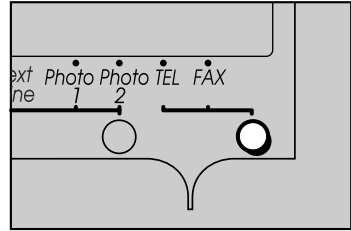

● Receiving calls in TEL Mode

When the machine is switched to TEL mode, follow these steps to answer incoming calls.



- 1** When the machine rings remove all documents from the ADF then, press



or lift the handset and listen.

- If you hear a voice and you lifted the handset, continue the conversation as normal and replace the handset when finished.
- If you hear another fax machine, make sure the machine is in fax operation mode (press Fax/Copy if necessary), then go to step 2.

Telephone call

- 2** Press  then press  or  until the display opposite appears .

Mode: Recep.? OK

- 3** Press  and replace the handset.

The machine will start receiving the message.

Connecting ...

Screening out Unwanted Faxes with Authorized Reception

This feature lets you screen out unwanted incoming fax messages. In this manual, the CSI of another machine which you wish to allow to send you fax messages is referred to as a Specified Sender. When Authorized Reception is turned on, your machine will only receive fax messages from Specified Senders—all other incoming messages will be rejected and not printed.

Note

If the other party has not registered their CSI or clears/changes it on their machine, you will not be able to receive any messages from them when Authorized Reception is turned on.

When a fax message comes in, the machine checks to see if the sender's CSI is stored in any of the Quick Dials or Name Dials. If it is found and you have used that Quick Dial or Name Dial to send at least one message to that destination, the message is accepted.

Note



You can store up to 30 Specified Senders (25 Name Dials and 5 Quick Dials).

To set up your machine for Authorized Reception, you need to:

- 1 Turn Authorized Reception on.**
- 2 Make sure all the Specified Sender CSIs are stored in Quick Dials or Name Dials.**
- 3 Make sure that you have sent at least one message to all the Specified Senders using their Name Dials or Quick Dials. After one message has been sent, the Specified Sender is enabled and you can receive fax messages from them.**

Note

If you turn Authorized Reception on and omit steps 2 and 3 above, the machine will not be able to receive any fax messages.

-  *Storing, Editing and Deleting Quick Dials, see page 56.*
-  *Storing and Deleting Name Dials, see page 61.*
-  *Unauthorized Call Report, see page 65.*

●Turning Authorized Reception on/off

1 Press  *Help/Function*.

Prt Help List ▶

2 Press Zoom .



Function no.: __

3 Press  **2**.

21 Author. RX 

4 Press *OK* .

Mode: Off? 

5 Press  *Zoom* or Zoom  to adjust the setting.

Mode: On? 

6 Press *OK* . The display opposite will flash briefly on the display and then the function menu will reappear.

Registered

Note

Do not carry out any operations while “Registered” appears on the display.

2 Communication 

7 Do one of the following.

- Enter another function number.
- Press  to return to standby mode.

Canceling Reception of a Fax

If for some reason you want to cancel reception of fax while it is being received, do the following.

1 Make sure the machine is in fax operation mode.

Recep. canceled

2 Press .

Note

A portion of the fax message may still be printed.

Making Telephone Calls

If you connect an optional telephone handset, you can use the same line for both telephone calls and fax messages.

Note

If you wish to be able to receive telephone calls, be sure to select TEL mode.

☛ *Choosing a Reception Mode, see page 46.*

1 Do one of the following:

- Pick up the telephone handset and dial with the handset keypad
- Make sure the machine is in fax operation mode, pick up the telephone handset and dial using the operation panel numeric keypad, a Quick Dial, a Name Dial or the Pause/Redial key
- Make sure the machine is in fax operation mode, press the On Hook key and dial using a Quick Dial, a Name Dial or the Pause/Redial key. When the other party answers, pick up the telephone handset.

Note

In some locales, On Hook dialing is not available and/or you cannot dial using a Quick Dial, Name Dial, the number keys or Redial key when the handset is lifted.

2 Continue your conversation as usual.

Faxing During a Telephone Call

You can also have the machine take over the line and send or receive a fax message at the end of your telephone call. This is useful when:

- The other party shares their line with a similar fax machine and you wish to send or receive a message after your conversation.
- You wish to check that the number is indeed a fax number before attempting to send your message.

Note

The other party's machine must support this feature.

1 Do one of the following:

- Pick up the telephone handset and dial with the handset keypad
- Make sure the machine is in fax operation mode, pick up the telephone handset and dial using the operation panel numeric keypad, a Quick Dial, a Name Dial or the Pause/Redial key
- Make sure the machine is in fax operation mode, press the On Hook key and dial using a Quick Dial, a Name Dial or the Pause/Redial key. When the other party answers, pick up the telephone handset.

Note



In some locales, On Hook dialling is not available and/or you cannot dial using a Quick Dial, Name Dial, the number keys or Redial key when the handset is lifted.

2 Listen to the line.

- If a voice answers, continue your conversation as normal.
- When you wish to send a fax, listen for the fax tone of the other party, then continue from step **3** below.
- When you wish to receive a fax, listen for the fax tone of the other party, then continue from step **7** below.

● Sending a Fax during a Telephone Call**3 Make sure the machine is in fax operation mode, set your document and adjust any scan settings as required.**

Mode: Trans. ? OK

4 Press .**5 If the display opposite is not shown, press  Zoom or Zoom  until it is.****6 Press *OK*  then replace the handset.**

Connecting...

**7 Press *OK*  then wait until the following display appears.
Replace the handset.****● Receiving a Fax during a Telephone Call****8 Make sure the machine is in fax operation mode and remove all documents from the ADF**

Mode: Trans. ? OK

9 Press .

Mode: Recep. ? OK

10 If the display opposite is not shown, press  Zoom or Zoom  until it is.**11 Press *OK* .
Replace the handset.**

Connecting...

Monitoring the Line while Dialing with On Hook

This feature lets you dial a telephone number without lifting the optional external handset. You can listen to what is happening on the line through the machine's internal speaker.

- 1** If necessary, press  to switch to fax operation mode.

Dial/Set orig.

- 2** Press  .

Dial number

- 3** Dial the telephone number using the numeric keypad, a Quick Dial, a Name Dial or the Pause/Redial key.

12345

- 4** If you hear a voice answer, pick up the external handset, press  again and continue your conversation.

- To cancel the call, press  .

- 5** Replace the handset when you have finished the call.

Dial/Set orig.

Remote Change

If you have set the reception mode to TEL mode and turn this feature on, you can use the telephone handset numeric keypad to start fax reception when you hear another fax machine on the line.

When you hear a fax machine through the handset, press the Remote Change digit on the telephone handset twice to initiate fax reception, then replace the handset.

You need to specify the Remote Change digit using when you turn this feature on with the following procedure.

1 Press  *Help/Function*.

Prt Help List ▶

2 Press Zoom .



Function no.: __

3 Press  .

32 Remote Change

4 Press *OK* .

Mode: Off? ^{OK}

5 Press  *Zoom* or Zoom  to turn Remote Change on or off.

Mode: On? ^{OK}

6 Press *OK*  and do one of the following:

- If you turned Remote Change on, go to step **7**.
- If you turned Remote Change off, go to step **3**.

Change with 2 ^{OK}

7 Press a digit on the numeric keypad to select the Remote Change digit.

E.g. press .

Change with 7 ^{OK}

8 Press *OK* . The display opposite will flash briefly on the display and then the function menu will reappear.

Registered

 **Note**

Do not turn off the machine while “Please wait” or “Registered” is shown on the operation panel display.

3 Fax Switch ^{OK}

9 Do one of the following.

- Enter another function number.
- Press  *Help/Function* to return to standby mode.

Storing Fax and Telephone Numbers

This machine provides two useful methods for storing fax and telephone numbers:

- Quick Dials
- Name Dials



Note

The maximum length of a fax number you can dial, or store in Quick Dials/Name Dials, is 40 digits.

Quick Dials

If you often dial certain numbers, you can save time and effort by storing them in Quick Dial keys. Once stored, instead of entering a fax number directly on the numeric keypad, just press the Quick Dial key the number is stored in.

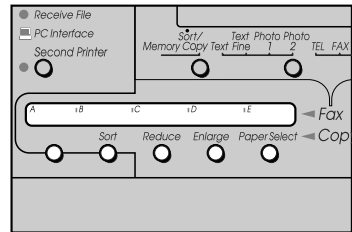

If you store a number in a Quick Dial, you can also give it a name up to 10 characters long.

If you press a Quick Dial key when the display opposite is shown, the stored name will come up on the display so you can check it.

Dial/set orig.

B:XYZ CO.

You can store one fax number in each of the five Quick Dial keys labeled A-E. To check the fax numbers stored in Quick Dials, print out the Dial List.

☛ *Printing the Dial List, see page 64.*

☛ *Name Dials, see page 59.*

☛ *For how to dial with a Quick Dial, see page 55 step 5.*

● Storing Quick Dials

☛ *Entering Characters on the Operation Panel, see page xiv.*

☛ *Entering Pauses and Tones in Fax Numbers, see page 43.*

1 Press *Help/Function*.

Prt Help List ▶

2 Press *Zoom* .

Function no.: __

3 Press *1* *3* .

13 Quick Dial

4 Press *OK* .

Press Quick or



Print List ▶

5 To select a Quick Dial, press a Quick Dial key.

E.g. press *Sort/Memory Copy* to select Quick dial (1B).

B:■

Note

To print a list of currently stored Quick Dials, press *Zoom* .

Dial List



Press Start

Then press .

Printing...

6 Enter or edit the fax number you wish to store with the numeric keypad.

E.g. press *1* *2* *3* *4* *5* *6* *7* *8* *9* .







123456789■







7 Press **OK** .









B: ■





8 Enter or edit the name for this Quick Dial.

B: XYZ CO. ■

E.g. press   Zoom    

Zoom      Zoom  

Zoom     Zoom    

Zoom    Zoom  

9 Press **OK** .

Registered

 **Note**



Do not turn off the machine while “Please wait” or “Registered” is shown on the operation panel display.

Print List 



Press Quick or

10 Do one of the following:

- To store another Quick Dial, go back to step **5**.
- To return to standby mode, press  twice.
- To access another function, press  then enter a function number.

●Editing Quick Dials

1 Press  .

Prt Help List 

2 Press Zoom  .

Function no.: __

3 Press  .

13 Quick Dial 

4 Press **OK** .

Print List 







Press Quick or

5 Press the Quick Dial key you wish to edit.

 234567989

6 Edit the fax number stored in this Quick Dial.

123451

- To move the cursor, press   Zoom or Zoom  .

Delete?





 Entering Numbers, see page 30.

 Dereting Characters and Moving the Cursor, see page xiv.

7 Press **OK** .

B: 

8 Edit the name stored in this Quick Dial.

- To move the cursor, press   Zoom or Zoom  .

B:XYZ

9 Press **OK** .

 **Note**

Do not turn off the machine while “Registered” is shown on the operation panel display.

Registered

Print List 



Press Quick or

10 Do one of the following:

- To edit another Quick Dial, go to step **5**.
- To return to standby mode, press  *Help/Function* twice.

● Clearing Quick Dials

1 Press  *Help/Function* .

Prt Help List ▶

2 Press Zoom  ▶.

Function no.: __

3 Press   ^{DEF}.

13 Quick Dial ^{OK}

4 Press *OK* .

Print List ▶



Press Quick or

5 Press the Quick Dial key you wish to delete

■2345

E.g. press *Sort/* *Memory Copy*  to select Quick dial (B).

6 Press *Clear* .

Delete?

 **Note**

If you do not wish to clear this Quick Dial, press  *Help/Function* twice to return to standby mode.

7 Press *OK* .

B: ■

8 Press  *Help/Function* twice to return to standby mode.

Name Dials

Name Dials are a handy way of storing fax numbers that you dial regularly in machine memory. When you store a number in a Name Dial, you must also give it a name up to 10 characters long. When dialing, you enter the first letter of this name to quickly find the Name Dial you require.

Office B

You can store multiple Name Dials with identical first letters and step through them to find the one you want when dialing.

You can store up to 25 Name Dials.

Note

You cannot store two Name Dials with the same name.

To check which Name Dials are currently stored, print out the Dial List.

☞ *Printing the Dial List, see page 64.*

☞ *Quick Dials, see page 54.*

● Storing Name Dials

☞ *Entering Characters on the Operation Panel, see page xiv,30.*

☞ *Entering Pauses and Tones in Fax Numbers, see page 43.*

1 Press  *Help/Function*.

Prt Help List ▶

2 Press Zoom .

Function no.: __

3 Press **1** **4**^{GH}.

14 Name Dial OK

4 Press OK .

Register? OK

5 Press OK .

■

6 Enter the fax number you wish to store with the numeric keypad.

123456789■

E.g. press 1 2 3 4 5 6 7 8 9

7 Press **OK**.

Name : ■

8 Enter or edit the name for this Name Dial.

E.g. press 9 Zoom + 9 Zoom + 9 Zoom + 0
 Zoom + 9 9 9 Zoom + 0
 Zoom + 2 2 2 Zoom + 6 6 6
 Zoom + 0 0 Zoom +

Name : XYZ CO. ■

9 Press **OK**.

Note

- Do not turn off the machine while “Registered” is shown on the operation panel display.
- If a Name Dial with the same name is already stored, “Name exists” will flash on the display. Enter a different name.

Registered

Register? OK

10 Do one of the following.

- To store another Name Dial, go back to step 4.
- To return to standby mode, press **Help/Function** twice.
- To access another function, press **Help/Function** once and enter another function number.

●Deleting Name Dials

1 Press  *Help/Function*.

Prt Help List ▶

2 Press Zoom .

Function no.: __

3 Press  .

14 Name Dial 

4 Press *OK*  Zoom .

Delete? 

5 Press *OK* .

Select letter

6 Enter the first letter of the Name Dial label.



Marty

E.g. press .

- If Name Dial you are looking for does not appear, keep pressing the key until it does.

E.g. press  again



Note

You can also search through Name Dials that begin the same initial letter with the  Zoom and Zoom  keys.

7 Press *Clear* .

Delete?



8 Do one of the following.

- To delete the Name Dial, press *OK*  and go to step **9**.
- To cancel this operation, press  *Help/Function* either enter another function number, or press  *Help/Function* to return to standby mode.

Deleted

1 Set up 

9 Do one of the following

- To delete another Name Dial, go to step **5**.
- To return to standby mode, press  twice.
- To access another function, press  once and enter another function number.

●Dialing with Name Dials

Instead of dialling the number on the numeric keypad, do the following in fax operation mode.

☛ How to Send a Fax, see page 40

1 Make sure the machine is in fax operation mode.

Dial/Set orig.

2 Press .

Select letter

2 Enter the first letter of the Name Dial label.

Marty

E.g. press .



- If the Name Dial you are looking for does not appear, keep pressing the key until it does.

E.g. press  again.

Main Off

Note

You can also search through Name Dials that begin the same initial letter with the

 Zoom and Zoom  keys.

Reports and Lists

Printing the Journal

The Journal is a record of fax messages that were recently sent or received by your machine. By default, it is printed automatically after every 35 communications.

You can print it out whenever you wish to check on machine usage, or to find out if a communication was successful or not.

The following items are included on the Journal:

- Own name—this machine's Own name/TTI identification
- Transmission—list of recent fax transmissions from this machine
- Reception—list of recent fax messages received by this machine
- Date and Time—when the communication took place
- Address—the fax number/identification of the other party
- Duration—how long the communication took
- Page—how many pages the message contained
- Result—whether the communication completed successfully

☛ For how to turn automatic printing of the Journal on/off, see User Parameters, see page 102.

1 Press  Help/
Function .

Prt Help List ▶

2 Press Zoom  ▶.

Function no.: __

3 Press **4**^{SH} **1** .

41 Journal

4 Press OK .

Press Start

5 Press  Start .

Printing...

Printing the Dial List

Print this list to check on the names and numbers of Quick Dials and Name Dials stored in the machine.

You can print the Dial list using the procedure below, or when storing Quick Dials.

The following items are included on the Dial List:

- Own name—this machine's Own name/TTI identification
- Own fax number—this machine's fax number
- Quick Dial—list of Quick Dial labels and numbers
- Name Dial—list of Name Dial labels and numbers

1 Press  *Help/Function*.

Prt Help List ▶

2 Press *Zoom* .

Function no.: __

3 Press  .

42 Dial List 

4 Press *OK* .

Press Start

5 Press .

Printing...

Transmission Result Report

By default, this report is turned off. If you turn it on, this report will be printed after every fax you send.

The following information is listed:

- From (Owner)—this machine's fax number/identification
- To—the destination fax number/identification
- Page(s)—number of pages in document
- Date, Time—when the communication took place

- Duration—how long the communication lasted
 - Result—whether the transmission was successful
- ☛ *To turn automatic printing of this report on or off, see Customising Default Settings with the User Parameters, see page 102.*

Error Report

By default, this report is printed automatically if a reception or transmission fails.

The following information is given:

- From (Owner)—the sender's fax number/identification
- To—the receiver's fax number/identification
- Date, Time—when the communication failure happened
- Duration—how long the communication lasted
- Reason for error

Power Failure Report

If power is lost while sending a message, receiving a message, or while a message has been stored in memory when the Receive File indicator is lit, this report will be printed out when power is restored.

☛ *When the Receive File Indicator is lit, see page 47.*

Unauthorized Call Report

If you have set up Authorized Reception, and turned this report on, a report is printed if an unauthorized sender tries to send you a message.

By default this report is turned off. Turn it on with the User Parameters.

☛ *Authorized Reception, see page 47.*

☛ *User Parameters, see page 102.*

The following items are recorded:

- From—the fax number/id of the sender
- Date, Time—when they tried to send the message

Advanced Features

Making Machine Sounds Louder or Quieter

This machine makes various sounds during operation. You can adjust the volume of these sounds, or turn them off completely according to your taste. You can change the following:

- TX—the sound of a fax being sent
- RX—the sound of a fax being received
- On Hook—sounds made when using the On Hook feature
- Dialling—tones you hear after pressing Start
- Buzzer—warning beep (e.g. when cover is opened) and the sound made every time you press a key on the operation panel
- Ring—ringing sound when a call comes in

Note

On Hook is not available in some locales.

1 Press  *Help/Function*.

Prt Help List ▶

2 Press *Zoom*  ▶.



Function no.: __

3 Press *3 DEF* .

31 Adjust Volume

4 Press *OK* .

TX: ■ OK

5 Press *Zoom*  ▶ or  *Zoom* to make the volume louder or quieter.

TX: ■■ OK

6 Press *OK* .

7 Repeat steps 5 and 6 for all adjustable volumes.

After adjusting the Ring volume and pressing OK , the display opposite will appear. Now go to step 8.

Registered

Note

Do not carry out any operations while “Registered” appears on the display.

8 Do one of the following:

- Enter another function number.
- Press  to return to standby mode.

3 FaxSwitch **Sending Faxes Over Unreliable Lines-Slow (4800bps)**

If you experience problems sending faxes due to bad telephone lines, you can reduce the speed at which your machine sends fax messages to 4800 bits per second.

Note

This setting does not affect the speed at which your machine receives faxes.

Use the following procedure to turn this feature on/off.

1 Press .

Prt Help List ▶

2 Press Zoom .



Function no.: __

3 Press  .

22 Slow(4800bps)

4 Press OK .

4800bps: No? ▶

5 Press Zoom  or  Zoom to adjust the setting.

4800bps: Yes? 

6 Press . The display opposite will flash briefly on the display and then the function menu will reappear.

Registered



Note

Do not carry out any operations while “Registered” appears on the display.

2 Communication^{OK}

7 Do one of the following:

- Enter another function number.
- Press  to return to standby mode.

RDS

RDS stands for Remote Diagnostic System.

If your machine has a problem, a service technician can perform various diagnostic tasks over the telephone line from the service station to try and find out what is wrong. The service technician can also use this feature to change some of your machine’s settings if you request it.

For this feature to work, you must turn it on before the service technician starts the RDS operation on your machine.

☛ For how to switch this feature on or off, see Changing On/Off Settings, see page 69.

Page Header

By default, your TTI/Own Number appears on top of faxes you send when printed at the other end. If you wish, you can turn this feature off.

☛ For how to switch this feature on or off, see Changing On/Off Settings, see above.

☛ Storing your Own Name/TTI, see page 33.

Changing On/Off Settings

Use this procedure to turn the following features on or off:

☛ Page Header, see above.

☛ Turning Summer Time (Daylight Saving Time) on/off, see page 39.

☛ RDS, see above.

1 Press  .

Prt Help List ▶

2 Press Zoom  ▶.



Function no.: __

3 Press  .

51 Select 

4 Press *OK* 

Page Header 



5 Press  *Zoom* or Zoom  ▶ until the setting you wish to change appears on the display.

E.g. press Zoom  ▶ once.

Summer Time 

6 Press *OK* 

Mode: Off? 

7 Press  *Zoom* or Zoom  ▶ to adjust the change.

Mode: On? 

8 Press *OK* . The display opposite will flash briefly on the display and then the function menu will reappear.

 *Note*

Do not carry out any operations while “Registered” appears on the display.

Registered

5 Select 

9 Do one of the following:

- Enter another function number.
- Press  to return to standby mode.

5. COPYING

Making a Copy

1 Lift the platen cover (①). Place the original face down at the arrow mark on the scale (②). Close the platen cover (③).

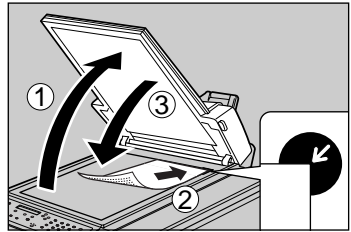

2 Press  to perform the copy operation.

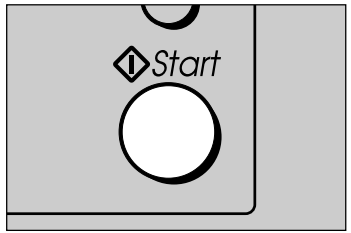

Important!

After copying a large number of pages, wait a couple of minutes before attempting to turn off the machine.

Note

When printing to label paper, envelopes, transparencies, or thin paper (60 g/m² or 16 lb), remove each printout as it comes out of the machine. If you don't, printed output can fall out of the output tray, and become curled.

Alignment of Originals

Align the original with the scale of the exposure glass.

- When the original is a standard size such as A4 or Letter, align it to the indexes on the scale.
- When your original is not standard size, align the upper left edge of the original to the arrow mark on the scale.

Making Multiple Copies

- 1** Lift the platen cover (①). Place the original face down at the arrow mark on the scale (②). Close the platen cover (③).

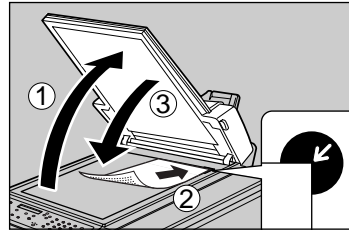

- 2** Enter the number of copies you wish to make using the numeric keypad.

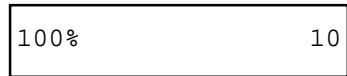

E.g. to make ten copies, press **10**.

Note

If your document is not scanned in even when you press , there is a chance it is not set correctly in the ADF. Reset your document and try again. For how to set documents in the ADF, see page 73.

- 3** Press  to perform the copy operation.

Note

During the copy operation, the display shows the number of copies printed so far and that to be printed. For example, 02/10 appears while the second copy of a run of 10 copies is being printed.

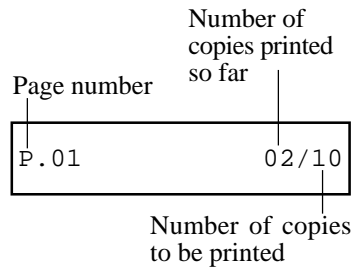

Tips

- After copying finishes, press  to clear any settings.

Making a Book Copy

When copying from a book, the thickness of the book should be no more than 30mm (1.18").

1 Lift the platen cover.

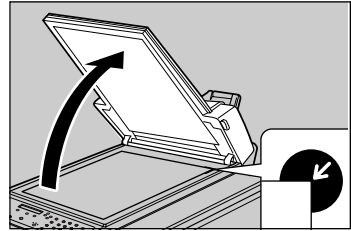

2 Open to the page you want to copy and lay the page face down on the exposure glass. Be sure to align one of the corners of the page with the arrow mark on the scale.

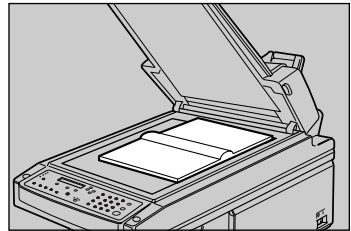

3 Lower the platen cover.

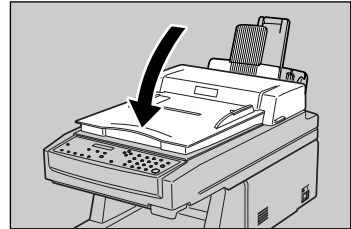

4 Press  to perform the copy operation.

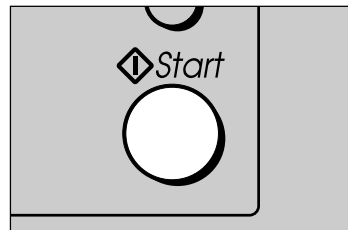

Reduction and Enlargement

Press ^{Reduce} or ^{Enlarge} to select preset reduction or enlargement factors for the copy operation.

To Set the Reduction Factor

1 Lift the platen cover (1). Place the original face down at the arrow mark on the scale (2). Close the platen cover (3).

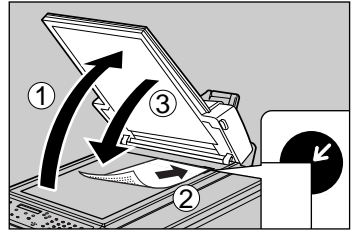

2 Press ^{Reduce} until the desired size ratio appears. The sizes change in the following order.

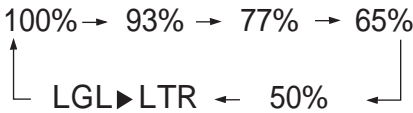
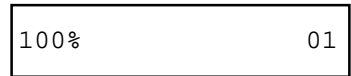

3 Press ^{Start} to perform the copy operation.

Note

After copying finishes, press ^{Clear Modes} to clear any settings.

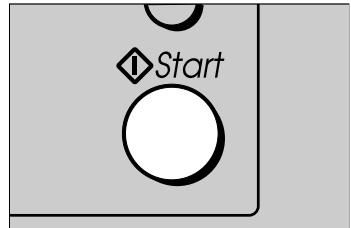

To Set the Enlargement Factor

- 1** Lift the platen cover (①). Place the original face down at the arrow mark on the scale (②). Close the platen cover (③).

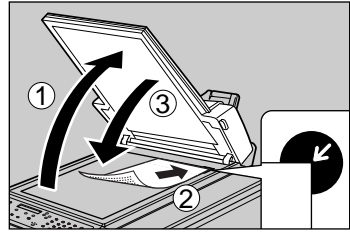

- 2** Press ^{Enlarge}  until the desired size ratio appears. The sizes change in the following order.

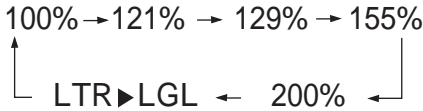

- 3** Press ^{Start}  to perform the copy operation.

Note
 After copying finishes, press ^{Clear Modes}  to clear any settings.

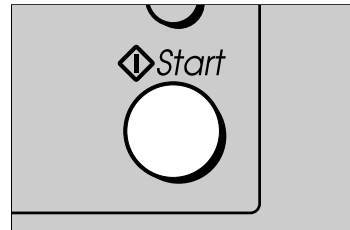

Zoom (In 1% Increments)

Zoom allows you to tune the preset reduction and enlargement factors to exactly the value you want. You can change the zoom factor in increments of 1%.

To Use Zoom

Setting Range

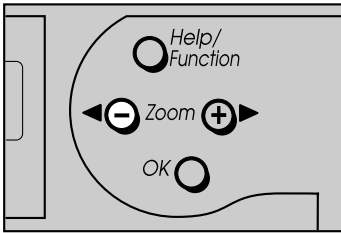

200 to 50%

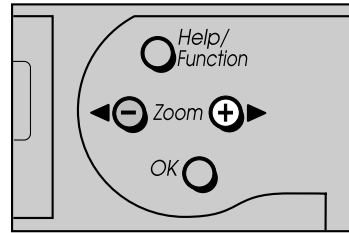

50 to 200%

- 1** Lift the platen cover (①). Place the original face down at the arrow mark on the scale (②). Close the platen cover (③).

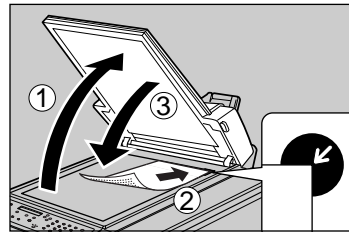

- 2** Press **Zoom** (decrease) or **Zoom** (increase) until the desired size ratio appears.

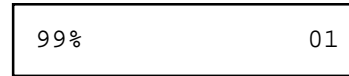
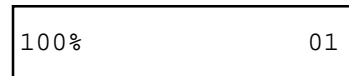

- 3** Press **Start** to perform the copy operation.

Note

After copying finishes, press

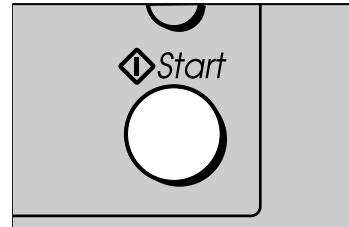

Adjusting the Copy Image

To Select the Resolution/Photo Setting

1 Lift the platen cover (①). Place the original face down at the arrow mark on the scale (②). Close the platen cover (③).

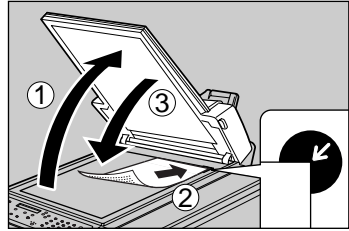

2 Press the Original Type Select key to specify the resolution or halftoning method for the copy operation.

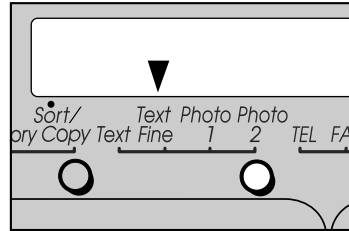

3 A pointer (▼) moves on the display to indicate the current setting. Choose a setting that matches your original:

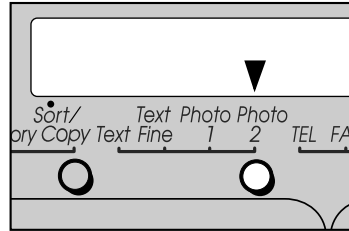

Setting	Use for:
[Text Fine]	Copying text
[Photo1]	Copying photographs
[Photo2]	Copying mixed text and photographs

Note

If the memory size of your machine is 4MB, the machine automatically switches from Photo2 to Photo1 when you make multiple copies using the ADF.

4 Press  to perform the copy operation.

Note

After copying finishes, press  to clear any settings.

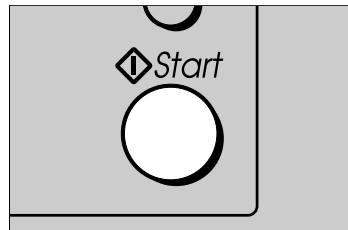

To Adjust the Image Density

- 1** Lift the platen cover (①). Place the original face down at the arrow mark on the scale (②). Close the platen cover (③).

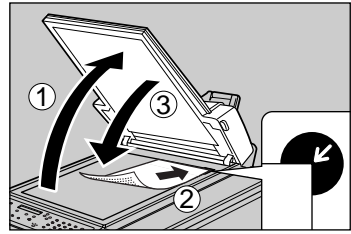

- 2** Press the Density key to select the image density.

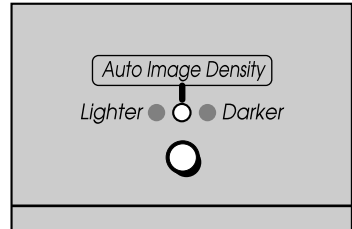

- Select [Lighter] to make the image lighter.

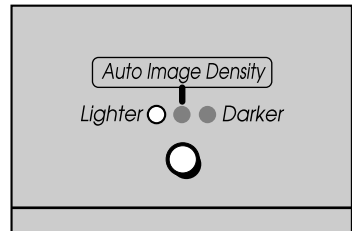

- Select [Darker] to make the image darker.

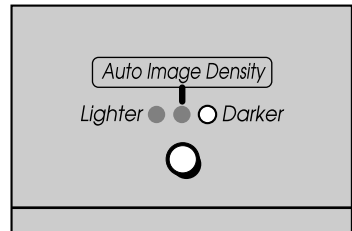

- 3** Press  to perform the copy operation.

Note

After copying finishes, press  to clear any settings.

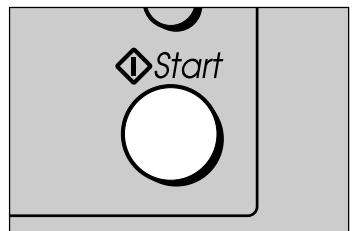

Setting an Original on the ADF

You can load up to 10 sheets of plain paper (80 g/m² or 20 lb) at a time into the Automatic Document Feeder (ADF).

Important!

Check to make sure that the ADF cover is securely closed before using it.

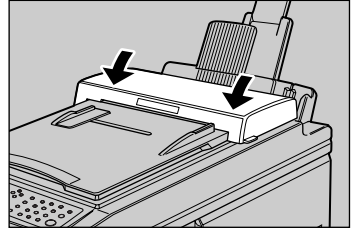

- 1 Fan the stack of originals. Never try to place more than 10 sheets of plain paper onto the ADF.**

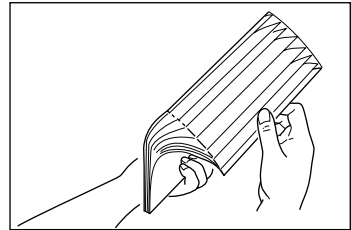

- 2 Straighten up all four sides of the stack, by tapping them on a desk or table top.**

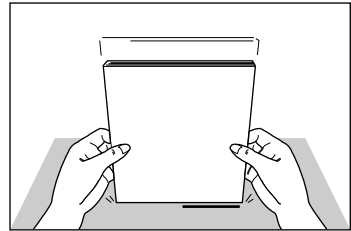

- 3 Place the stack of originals face down on the ADF and slide the document guide against the side of the stack.**

Note

The side of the original to be copied should be face down.

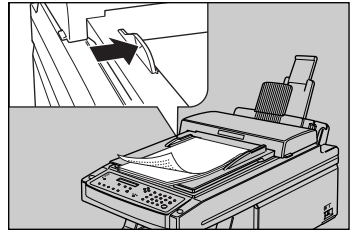

- 4 Insert the stack of originals along the document guide into the ADF.**

Note

Insert your stack of originals into the ADF until it stops. If you do not push it right in, the machine will not detect the stack.

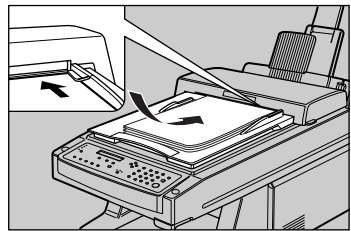

- 5** Make sure the upper tray extension is pulled out.

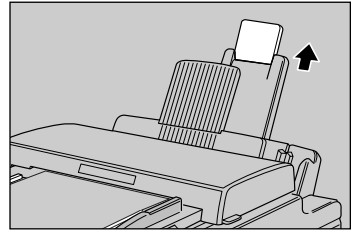

- 6** Press  to perform the copy operation.

 **Note**

- If your original jams while being fed into the ADF, press  to cancel the operation. See page 43 for how to clear the jam.
- We recommend you use Text mode when copying with the ADF.

 **Note**

We recommend you copy photo originals from the exposure glass for best results.

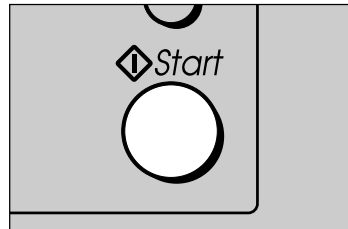

Originals that do not meet the following requirements can cause paper misfeeds, and even damage the machine.

■ **Requirements**

- | | |
|---------------------|---|
| • Thickness | 0.05mm to 0.2mm (0.002" to 0.08") |
| • Weight | 60 to 90 g/m ² (16lb to 24lb) |
| • Clear markings | Markings on the originals must be clear to be read correctly. |
| • Uniform page size | All pages should be the same size. |
| • Page condition | Avoid using originals that are bent, curled, damaged, or stapled, and originals printed on coated paper, carbon paper, or photographic paper. |

Sorting Output

The following example shows how output is affected by turning sorting on and off.

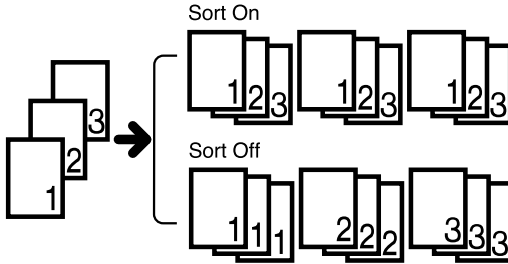

Important!

The sort operation requires scanning of all your originals into memory before starting the copy operation. The number of originals that can be scanned at one time depends on how much memory you have installed. Refer to page 21 for details on increasing memory capacity.

Sort Copying

1 Set the originals on the ADE

Note

Refer to page 78 for how to set originals.

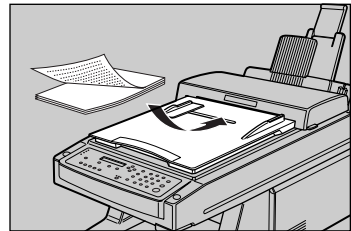

2 Sorting is activated when the ▼ pointer is visible on the display above Sort/

Memory Copy. Press **Sort/ Memory Copy** to turn sorting on.

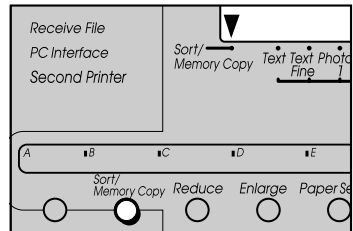

3 When you press  to start the copy operation, all of the originals on the ADF are scanned into memory before they are printed.



Note

After copying finishes, press

Clear Modes



to

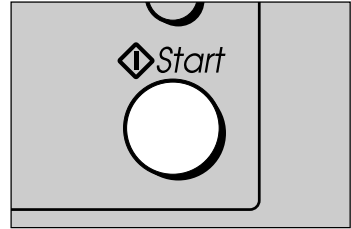

6. TROUBLESHOOTING

General

Status	Cause	Remedy	Page
Nothing happens when the machine is turned on.	Power cord is not connected.	Correctly connect the power cord to the machine and plug it into a outlet.	p.9
	SIMM is not installed correctly	Install the SIMM correctly	p.23
	SIMM does not meet the required specifications.	Use a SIMM with the required specifications.	p.23
Paper misfeeds when the machine is turned on for the first time after the installation.	Paper was loaded in the machine before the machine was turned on.	Remove the paper, turn the machine off and then back on. After machine initialization is complete, load the paper back into the machine.	p.9
After installing a SIMM board, the memory value that appears on the machine's display does not match the amount of memory installed.	SIMM does not meet the required specifications.	Use a SIMM with the required specifications.	P23

Printing and Copying (1/2)

Status	Cause	Remedy	Page	
Frequent paper misfeeds.	The upper paper tray is not set correctly	Set the upper paper tray correctly.	p.6	
	Improper paper.	Use paper of the correct size and thickness.	p.10	
	Paper is not set correctly in the upper paper tray.	Realign the paper with the paper guide, and if necessary, fan the paper stack.	p.11	
	Paper is curled or damp.	Uncurl the paper.		p.11,13,19
		Insert paper into the upper paper tray from the least-curved side.		p.11,13
		Set paper face down if necessary.		p.11,13,19
	Avoid using damp paper.		—	
	Too much paper is loaded in the machine.	Remove some of the paper.		p.11,15
Paper is loaded incorrectly.	Check the paper and realign it if necessary.		p.11,19	

Printing and Copying (2/2)

Status	Cause	Remedy	Page
Frequent paper mis-feeds.	Attempting to print on both sides of the paper.	Print on only one side. Two-side printing is not supported by this machine.	p.11,19
	Printing onto loosely stacked envelopes.	Flatten the envelopes to expel all air.	p.15
	Misfeeding of the envelope flap.	Make sure that envelope flaps are closed (folded down).	p.15
Part of the image is unclear.	Toner is distributed unevenly in the toner cassette.	Remove the toner cassette, gently rock it left and right a few times, and replace it into the machine.	p.97
Black lines on the printout.	Heat damage to the toner cassette caused by turning off the machine too soon after copying a large number of pages.	Replace the toner cassette.	p.97
Dark areas along the sides of the printout.	Turning off the machine too soon after printing or copying a large number of pages.	Replace the toner cassette.	p.97

Printing

Status	Cause	Remedy	Page
Abnormal or unexpected printing results.	Use of wrong cable.	Use the cable that comes with this machine.	p.7
	Wrong printer driver settings.	Change to the correct printer driver settings.	p.25
	Attempting to print from a DOS application at 600 dpi.	Change to 300 dpi.	p.105
Parts of the image are not printed out.	The correct paper size is not specified .	Specify the paper size using the operation panel.	p.20
Cannot print from a second printer.	Second printer is not connected correctly.	Check connections and make corrections, if necessary.	p.16
	Second printer is not selected.	Press ^{Second Printer}  so the indicator above it is lit.	p.28
	Incorrect settings of the second printer driver.	Use the printer driver of the second printer to turn off bi-directional printing.	p.28

Copying and Faxing (1/2)

Status	Cause	Remedy	Page
"Error 90" appears on the display, and the copy operation is aborted when copying from the exposure glass.	Locked scanner.	Unlock the scanner lock, turn the machine off and then back on.	p.3
Frequent original mis-feeds with ADF	Original is not set correctly.	Set the original correctly.	p.41,78
	Curled original(s).	Straighten out the original(s).	p.41,78
		Insert the original(s) from the least-curved side.	p.41,78
	Incorrect original specifications.	Use originals of the correct size, thickness, and quantity.	p.79
Original is not fed from the ADF	ADF cover is open.	Close the ADF cover.	p.78
	Document is not set correctly in ADF	Set the document properly.	p.41,78
Original is not fed out properly.	The document output tray is not set correctly.	Set the document output tray and the small pieces of plastic film correctly.	p.5
Periodic black marks on printed output.	Cleaning pad is not installed.	Correctly install the cleaning pad.	p.97
Black lines and marks on printed output when copying from the exposure glass.	Copying to small-size paper.	Place a sheet of the same size as the paper you are printing onto behind the original.	p.70
	Different size original and copy paper.		
	Non-white original background.	Adjust the print density.	p.77
	Dirty platen cover or exposure glass.	Clean the platen cover and exposure glass.	p.96
Black and white lines on printed output when using the ADF.	Dirty ADF transport path.	Clean the ADF transport path.	p.96
Output too light.	Low contrast original.	Adjust the print density.	p.77
Unclear photographic images.	Copying in Text Fine Mode.	Use the Original Type Select key to select the Photo1 or Photo2 Mode.	p.76
Parts of the original image are not copied.	The correct paper size is not specified	Specify the paper size using the operation panel.	p.20

Copying and Faxing (2/2)

Status	Cause	Remedy	Page
Cannot send or receive faxes.	The power is off.	Turn on the power.	p.9
	The machine is not connected to the telephone line.	Check the line connection. Make sure that one end of the line cable is connected to the LINE socket at the rear of the machine and the other to your telephone line socket.	p.32
	The Dial Mode settings are not correct.	Make sure you have selected the correct line type (pulse or tone). If behind a PABX, make sure the PABX settings are correct.	p.34
Cannot send faxes.	The machine is in copy operation mode.	Press the Fax/Copy key to switch to fax operation mode.	p.29
Cannot receive faxes	The machine is busy processing or printing a PC print job.	Fax reception is not possible while the machine is processing or printing PC print data.	
	The machine is busy making copies.	Fax reception is not possible while making copies.	
	The machine has run out of paper, or small size paper is loaded in the upper tray.	Load more paper. If small size paper is loaded, load A4 size paper so you can receive faxes.	p.11
	Toner has run out.	Install a new toner cassette.	p.97
	The machine is in TEL mode.	Press the Reception Mode key to switch to FAX mode, or read about how to receive faxes manually in TEL mode.	p.46
	Paper is jammed.	Clear all jammed paper.	p.91
	Top unit cover open.	Close all top unit.	p.3
	The machine has been set up to only receive faxes from certain senders with the Authorized Reception feature.	Turn Authorized Reception off with function 21, or read how to configure this feature.	p.47
Even when you press the Remote Change digit, Remote Change will not function.	Remote Change is not turned on.	Turn it on with function 32.	p.52
	You are pressing the wrong Remote Change digit, have pressed a key on the operation panel or the machine is busy dialling.	The default Remote Change digit is 2. If pressing this digit on the handset keypad still does not work, try changing the Remote Change digit to another number. Do not press any key on the operation panel before pressing the Remote Change digit. If the machine is busy dialling, Remote Change is not available.	p.52

Scanning





Status	Cause	Remedy	Page
PC scanning does not function properly.	The PC parallel port is not set to ECP.	Consult your PC manual on how to set your parallel port to ECP.	p.25

Error Messages (1/4)



The table below explains the error messages that may appear on the display and the appropriate action to take.

Message	Cause	Remedy	Page
“Close cover”	Top unit is open.	Close the top unit. If a copy job is in progress, set the copy quantity again.	P.3
“Add paper”	Machine is out of paper.	Load paper. If a copy job is in progress, set the copy quantity again.	P.11,19
“Toner near end”	Machine is almost out of toner.	Prepare a toner cassette for replacement.	—
“Add Toner”	Toner cassette is not loaded correctly.	Correctly load the toner cassette into the machine. If a copy job is in progress, set the copy quantity again.	P.2
	Machine is out of toner.	Replace the toner cassette.	P.97
“Clear paper”	Paper misfeed or paper will not feed at all.	Remove the misfed paper. If a copy job is in progress, set the copy quantity again. If paper persistently misfeeds, carry out the procedure on page 89.	P.91
“Memory overflow”	Not enough memory capacity. (PC printing only)	Either lower the printer driver Resolution setting, or increase memory capacity by installing a larger SIMM. Press any operation panel key to clear the error message from the display.	P.23
“Remove original” (when original is set in ADF)	Original misfeed or paper will not feed at all.	Remove the original from the ADF. If a copy job is in progress, set the copy quantity again.	P.78
“Original left” and “on glass”	An original may be left under the platen cover.	Open the platen cover, remove any original that remains, then lower the platen cover again.	—

Error Messages (2/4)

Message	Cause	Remedy	Page
"Memory full" and "Press Stop"	Too much sort copy data.	Press  to cancel sort copying. If you need to print big copy jobs, increase the memory capacity.	P.23, 80
	Too many sort copy pages.	Press  to print pages already stored in memory. To cancel the job, press  . If you need to print big copy jobs, increase the memory capacity.	P. 23,80
"Transm.error" and "Press Stop"	An error occurred during transmission, or the other line was busy. If power was lost during the dialing or connecting phases of transmission, or in fax transmission standby mode, this message will appear when you next turn the machine on.	Press  to clear the error message.	—
"Too many numbers"	Either the maximum number of Name Dials have been stored (25), or you tried to enter more than 40 digits for a destination fax number.	Delete some Name Dials or enter a shorter number.	P:59
"No connection"	The line is busy while dialing, connection failed, you dialed the wrong number, or there is no answer.	When scanning from the ADF, the machine will automatically enter redial mode. To cancel redialling, remove your document from the ADF.	P:52
"No loop current"	The line current was not detected-the line may not be connected.	Check the line connection.	P:8
"Printer in use"	The machine is busy printing.	Wait until it has finished and try again.	—
"Machine busy"	The machine is busy communicating.	Wait until the current operation has finished and try again.	—

Error Messages (3/4)

Message	Cause	Remedy	Page
"Name exists"	The name you input for this Name Dial already exists.	Either use a different name, or delete the other Name Dial and try again.	P.59
"Unable"	The machine is unable to print the report or list because there is a problem with the printer.	Press  to exit function mode and rectify the problem indicated on the display.	—
"Check fax no." and "Press Stop"	Multiple attempts at communication with this number failed.	Press  to cancel the transmission. In some locales, if this number was stored in a Name Dial, Quick Dial, or the redial memory, the number will be erased completely from the machine memory to comply with regulations. Check the number is correct and store it again if necessary.	—
"No dial tone"	No dial tone was detected.	Check the line connection and if behind a PABX, the PABX settings.	P.34
"Set A4 paper"	Small size paper is loaded in the upper tray (A4 size paper is required for receiving faxes)	Load A4 size paper in the upper tray and register the correct paper size setting.	p.11
"Set paper size"	The actual length of the paper is less than the registered paper length.	Make sure the registered paper size matches the paper loaded and register the correct paper size setting.	p.20
"Error" and "Press Stop"	An error occurred during reception.	Press  to clear the error message and inform the other party to send their fax again.	—
"Not registered"	The Redial memory or pressed Quick Dial key is empty.	Print the Dial List to check on which Quick Dials have numbers stored in them.	p.54, 64
"Name: No entry"	No name Dial exists with the initial letter you selected.	Make sure you selected the correct search letter for this Name Dial. You also can print the Dial List to see currently stored Name Dials.	p.54, 64

Error Messages (4/4)

Message	Cause	Remedy	Page
"Error 90"	Locked scanner.	Unlock the scanner lock, turn the machine off and then back on.	P.4
"Error XX"	Possible machine defect.	Turn power off and then back on again.	P.9
	There is a problem with your machine.		

If you have a problem with the machine and you cannot resolve it by referring to the information in this chapter, please contact your service representative.

If an "Error XX" message is displayed, be sure to turn off the machine before calling.

When the Receive File Indicator is Lit

This indicator lights to inform you that a page of an incoming fax message could not be printed for some reason (e.g. paper has run out) and that page has been stored in memory.

Important!

The machine cannot receive any more messages until you solve the problem. Turning off the power will erase any message stored in memory.

To print the page out, check the display and rectify the problem (e.g. paper has run out). When the problem is resolved, the page will automatically be printed out.

Note

If there is not enough memory, all or some parts of the message will not be stored or printed.

The machine will only store a page in memory if a problem occurs while reception is in process. The line will be disconnected immediately and following pages of the same message will not be received.

Clearing a Paper Misfeed

This section describes how to clear a paper misfeed when one occurs.

CAUTION

When removing misfed paper, do not touch the fusing section because it could be very hot.

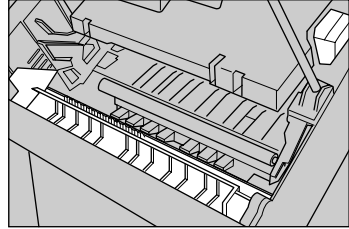

Important!

Hold a misfed sheet with both hands and slowly pull it out. Do not use a tool, such as a screwdriver or tweezers as this may damage the unit.

Note

If “Clear Paper” is still displayed after you clear the jam, there may be paper jammed in another part of the machine. Check all areas described in this section

Clearing a Feed in the Main Unit

- 1** Pull the top release lever (①) and open the top unit (②).

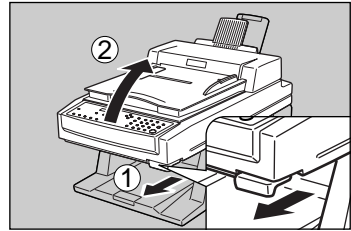

- 2** Pull out the toner cassette.

Note

- Be sure to hold the toner cassette by its handle.
- Keep the toner cassette horizontal to avoid spilling the toner.

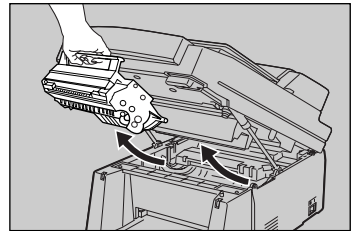

3 Push back the blue paper release lever located on the right.

Note

The lever releases pressure on the paper. If you do not push it back, you could damage the machine when removing paper.

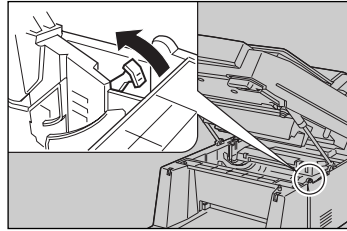

4 Pull out the misfed paper in the directions indicated by the arrows in the illustrations.

Note

- If you are using the paper feed unit (option) and cannot clear the misfeed using this procedure, use the procedure on page 93 instead.
- If toner gets on your hands, wash them immediately.

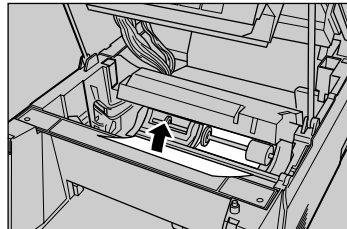
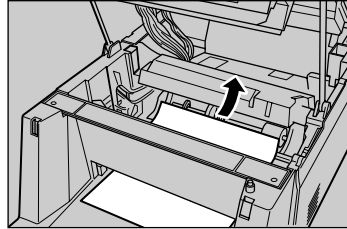

5 Install the toner cassette into the machine.

Note

- Be sure to hold the toner cassette by its handle.
- Keep the toner cassette horizontal to avoid spilling the toner.
- Refer to page 2 for details on how to install the toner cassette.

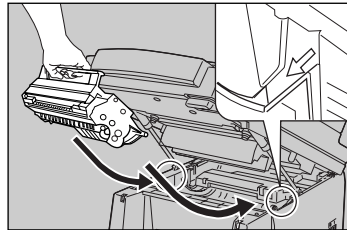

6 Close the top unit.

Note

If "Clear Paper" is still displayed after you clear the jam, there may be paper jammed in another part of the machine. Check all areas described in this section

Important!

If a paper misfeed occurs during a copy job, be sure to specify the desired copy quantity again.

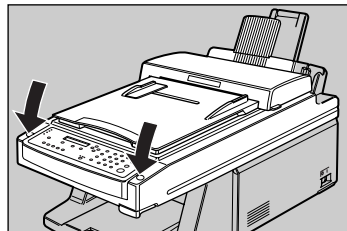

Clearing a Misfeed in the ADF

1 Open the ADF cover.

Note

Be sure to open the ADF cover before pulling out the misfed original. Failure to do so can result in damage to the original.

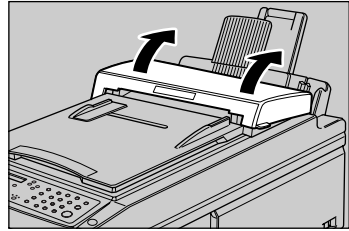

2 Pull out the misfed original.

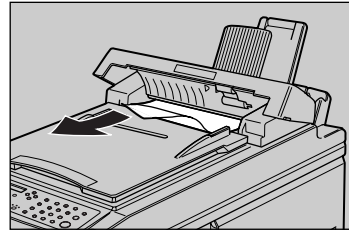

3 Close the ADF cover, and make sure it locks securely into place.

Important!

If copying was in progress, be sure to specify the desired copy quantity again.

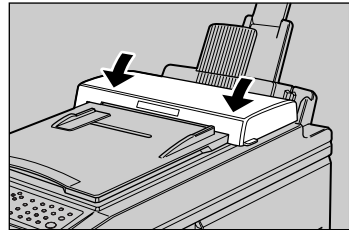

Clearing a Misfeed in the Optional Paper Feed Unit

1 Pull out the paper tray.

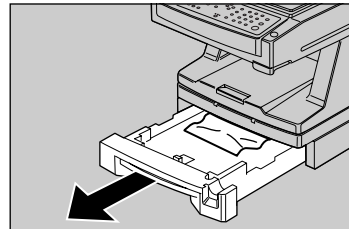

2 Pull out the misfed paper.

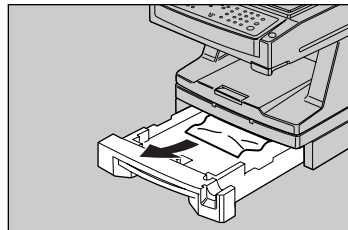

- 3** Slide the paper tray back into the paper feed unit until it locks into place.



Note
For how to set paper in the optional paper feed unit, see page 19.

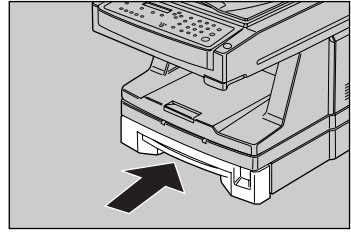

Tip

If you cannot find a remedy for unexpected printout results here, check the printer driver's online help for other useful information.

When Paper Will Not Feed

If paper has completely stopped feeding, check using the following procedure.

- 1** Remove all paper.

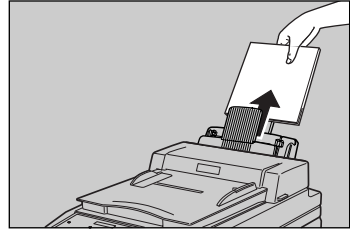

- 2** Pull the top release lever ① and open the top unit ②.

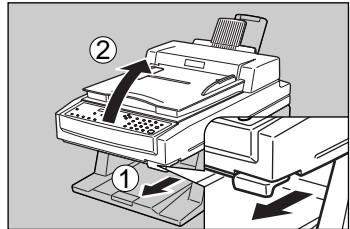

- 3** Pull out the toner cassette.

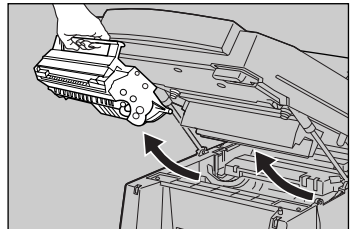

- 4** Pull the blue key-shaped pawl located deep inside on the right where the toner cassette was set forward.

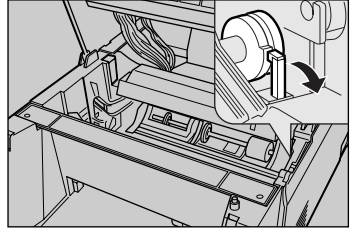

- 5** Install the toner cassette into the machine.

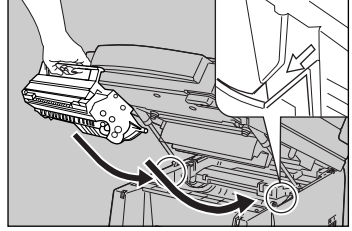

- 6** Close the top unit.
When the top unit is closed, the motor will start running. When the sound of the motor stops, set paper in the original position and continue with normal operation.

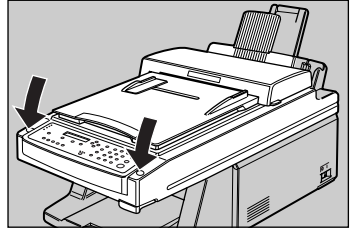

7. USER MAINTENANCE

Daily Maintenance

Clean with a damp cloth and wipe dry.

 **Note**

Turn off the machine before cleaning

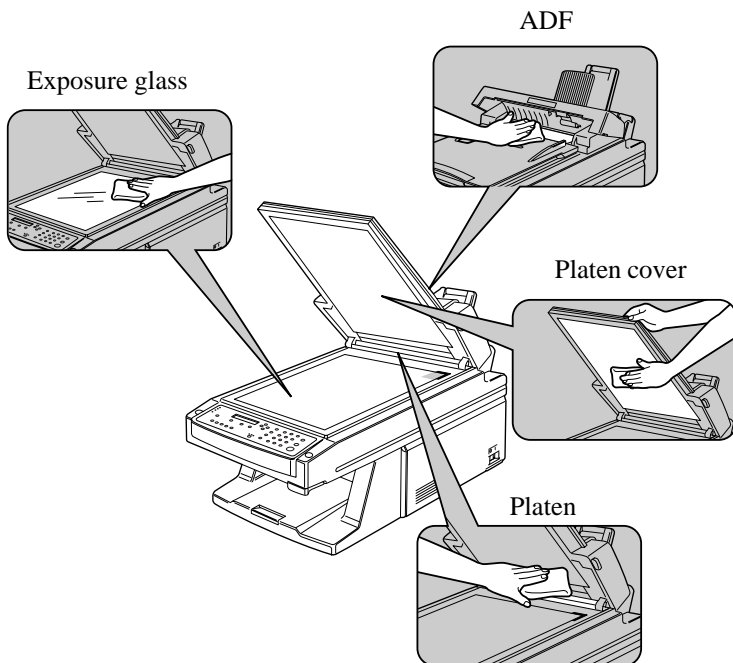

Replacing the Toner Cassette And the Cleaning Pad

Printing on A4 size paper under the recommended temperature and humidity conditions noted in the table under “Environment” on page 1, you can expect a toner cassette to print approximately 3,000 pages when you are printing typical business letters that have text covering 5% of the total surface. The starter cassette that comes with the machine can print approximately 1,000 pages. Pages that contain graphics use more toner and shorten the life of a toner cassette.

⚠ WARNING

- ⊘ Do not incinerate used toner or toner containers. Toner dust might ignite when exposed to an open flame. Dispose of the used toner cassettes according to local regulations for plastics.
- ⊘ This machine has been tested for safety using this supplier's parts and consumables. We recommend you only use these specified supplies.

⚠ CAUTION

When replacing the toner cassette and cleaning pad, do not touch the fusing section because it could be very hot.

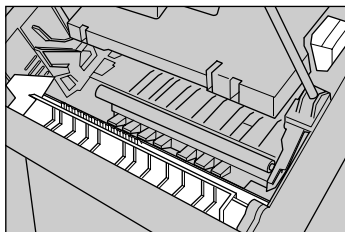

- 1** Open the box of the new toner cassette and check to make sure it contains a toner cassette and cleaning pad.

Note

Be sure to hold the toner cassette by its handle.

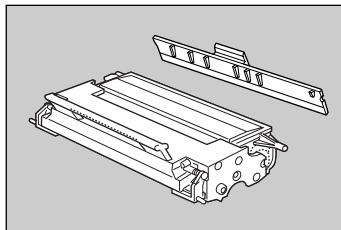

- 2** Pull the top release lever (1) and open the top unit (2).

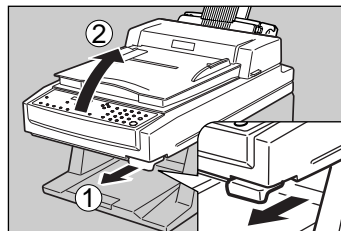

- 3** Hold the toner cassette by its handle and pull it out.

 **Note**

Keep the toner cassette horizontal to avoid spilling the toner.

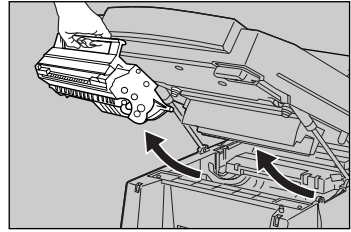

- 4** Remove the old cleaning pad.

 **Note**

Be sure to grasp the green handle when removing the cleaning pad.

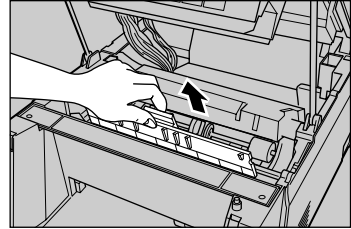

- 5** Grasp the new cleaning pad by the green handle and insert it into place.

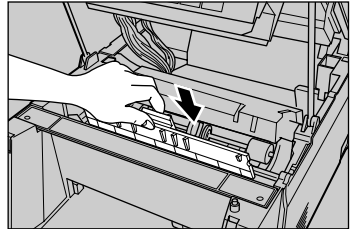

- 6** Press down gently but firmly on both sides of the pad to make sure that it is inserted as far as it can go.

Do not forget to install the cleaning pad whenever you install a new toner cassette.

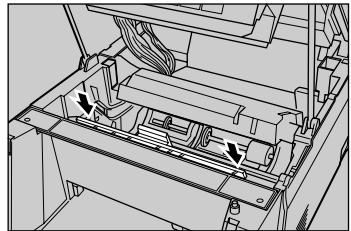

- 7** Prepare the new toner cassette. Holding the toner cassette by its handle, gently shake it side to side 5 or 6 times to evenly distribute the toner inside.

 **Note**

Be sure to hold the toner cassette by its handle.

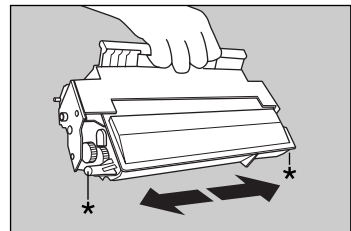

- 8** Look inside the machine and note the locations of the arrows that indicate the toner cassette guides on either side.

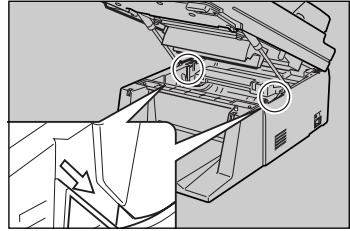

- 9** Make sure the plastic pins (marked with “*” in the illustration next to step above) on either side of the toner cassette slide along the guides inside the machine.

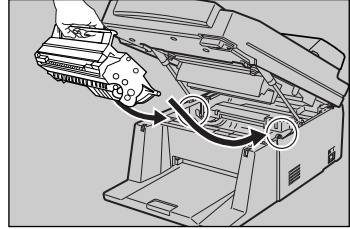

 **Note**

Be sure to hold the toner cassette by its handle.

- 10** To close the top unit, press down firmly but gently on both sides of it until the top unit closes and clicks securely into place.

 **Note**

Background gray cast is sometimes evident just after installing a new toner cassette.

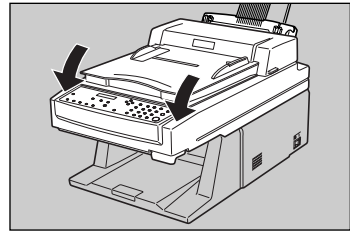

Storage

Paper

Paper should always be stored properly. Improperly stored paper might result in poor image reproduction, creased copies, or paper misfeeds. Generally, avoid paper curling and absorption of moisture.

- Avoid storing paper in humid areas. In high-temperature and high-humidity, or low-temperature and low-humidity conditions, store paper in a vinyl bag.
- Do not store paper where it will be exposed to heat.
- Store on a flat surface.
- Use older stock first.
- Do not lay heavy objects on paper.
- Keep open reams of paper in the package, and store as you would unopened paper.

Toner Cassette

- Keep the toner cassette inside the packaging that it comes packed in whenever it is removed from the machine.
- Store horizontally in a cool, dark place.
- Never store a toner cassette where it will be exposed to heat.
- Do not lay heavy objects on the toner cassette.

 CAUTION
Keep toner cassettes out of children's reach.

8. TECHNICAL REFERENCE

Printing the Help List

Print this list to get a quick guide to frequently used fax features.

- 1** While the machine is not performing any other operation, press  *Help/Function*.



- 2** Press *OK* .

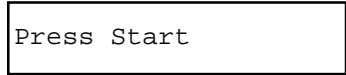

- 3** Press  *Start* to print the Help List.



Note

Print on A4, Letter, or Legal paper.

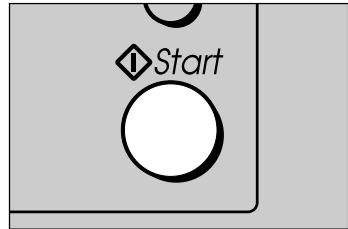

Customising Default Settings with the User Parameters

Changing the User Parameters

The User Parameters allow you to customise various machine settings and features to suit your requirements. They are four User Parameter Switches numbered 00 to 03. Each switch has 8 adjustable “bits” which can set to either 0 or 1.

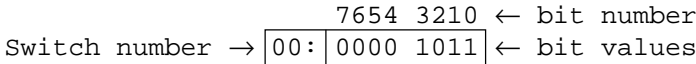

☞ For the meaning of each bit and how changing them affects the machine, see page 103.









 **Note**

Take care when changing the switch values. Only change the bits whose meanings are described in this manual.

 **Note**

Do not turn off the power while adjusting the User Parameter bit switches.

The following procedure describes how to change the User Parameters.

- | | |
|---|--|
| <p>1 Press  <i>Help/Function</i>.</p> | Prt Help List ▶ |
| <p>2 Press Zoom .</p> | Function No.:__ |
| <p>3 Press  .</p> | 52 User Param. ^o _K |
| <p>4 Press OK .</p> | 00 :1000 1011 ^o _K |
| <p>5 Press  <i>Zoom</i> or Zoom  until the switch you wish to edit appears.
E.g. press Zoom  twice to show switch 02.</p> | 02 :1110 0000 ^o _K |

6 To toggle the value of a single bit, press the number on the numeric keypad that corresponds to the number of the bit you wish to change.

E.g. press **3^{DEF}** to change bit 3.

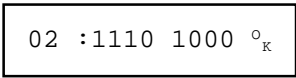

7 Press **OK** . The display opposite will flash briefly on the display and then the function menu will reappear.

 **Note**

Do not carry out any operations while “Registered” appears on the display.

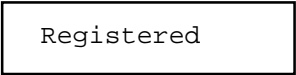
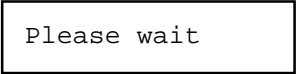

8 Do one of the following:

- Enter another function number.
- Press Help/Function to return to standby mode.



User Parameter Switch Summary

The following tables summarize the User Parameter bit switches and their meanings.

SWITCH 00 (1/2)

Bit	Explanation	Available Settings	Default	Notes
7	Width scanned when faxing a document	0: 210 mm (A4) 1: 216mm (IT/LG)	210mm (A4)	This setting takes effect from the next power on.
6	Display “Original left on glass.” Warning when scanning from the ADF and an original is left on the exposure glass	0: Yes 1: No	Yes	
5	Maximum length of document when scanning from the ADF	0: 400mm 1: 1200mm	400mm	This setting takes effect from the next power on.
4	Automatically print the Transmission Result Report after every successful transmission	0: No 1: Yes	No	

SWITCH 00 (2/2)

Bit	Explanation	Available Settings	Default	Notes
3	Automatically print the Journal after every 35 communications	0: No 1: Yes	Yes	
2	Print the Unauthorized Call Report when an unregistered caller tries to send you a fax (when Authorized Reception is switched on)	0: No 1: Yes	No	
1	Do not change this setting			
0	Automatically reduce received images to fit page	0: No 1: Yes	Yes*	* This function turned off by default in some locales. If you turn this function off, some parts of the printed image may be lost.

SWITCH 01

Bit	Explanation	Available Settings	Default	Notes
7	Copy/Fax Operation mode home position.	0: Fax 1: Copy	Copy	
6	Do not change these settings			
5				
4	Reset the image density and resolution to the values below after sending a fax, switching to fax operation mode or on power up.	0: No 1: Yes	Yes	These settings have no affect on the copy feature.
3 & 2	Image density home position when bit 4 above is 1.	b3 b2 0 0: Auto 0 1: Darker 1 0: Lighter	Auto	
1 & 0	Resolution home position when bit 4 above is 1.	b1 b0 0 0: Text (STD) 0 1: Text (Fine) 1 0: Photo 1 1 1: Photo 2	Text (STD)	

SWITCH 02

Bit	Explanation	Available Settings	Default	Notes
7	Do not change these settings			
6				
5				
4				
3	PCL Resolution Set the printer to 300 dpi if the designated output is not obtained when printing using a DOS application compatible with the 300 dpi PCL printer.	0: 600dpi 1: 300dpi	600dpi	
2	Toner Saving mode When Toner Saving is turned on, the machine prints using less toner. Use this mode if you wish to save on toner and do not mind lighter prints.	0: Off 1: On	Off	
1	Do not change these settings			
0				

8. TECHNICAL REFERENCE

SWITCH 03

Bit	Explanation	Available Settings	Default	Notes
7	Do not change these settings			
6				
5				
4				
3				
2				
1				
0				

Function List

Function Number	Function Name	Page Reference
11	Date/Time	38
12	Dial Mode	34
13	Quick Dial/Print Dial List	54
14	Name Dial	59
15	Language	107
16	Own name/TTI	33
17	Own Fax No.	36
21	Authorized Reception	49
22	Slow (4800bps)	67
31	Adjust Volume	66
32	Remote Change	52
41	Journal	63
42	Dial List	64
51	Page Header	68
	Summer Time	39
	RDS Mode	68
52	User Parameters	102
61	Tray Paper Size	11



Selecting the Language

1 Press  *Help/Function*.

Prt Help List

2 Press  *Help/Function*   *JKL*.

15 Language

3 Press *OK*  and press *Zoom*  or  *Zoom* until the desired language appears.

4 Press *OK* .

Registered

 **Note**

- Do not carry out any operations while “Registered” appears on the display.
- If you do not press *OK* , the setting is not changed.

1 Set up 

5 Press  *Help/Function* to return to the standby display.

Economy Mode

Economy mode is a power saving feature and is turned on by default. If no operation is performed for 5 minutes, the display becomes blank and all the indicators go out. If no operation is performed in the next 10 minutes or 235 minutes (according to the setting), the heater turns off.

Economy mode	Operation panel turns off after	Heater turns off after
ON (default setting)	5 minutes	15 minutes (including time when operation panel is off)
OFF	5 minutes	240 minutes (including time when operation panel is off)

 **Note**

- In Economy Mode, the heater turns back on in the following cases.
 - ◆ When any key on the operation panel is pressed
 - ◆ When the platen cover is opened
 - ◆ When paper is set in or removed from the upper paper tray
 - ◆ When the tray of the paper feed unit (option) is pulled out or pushed back into the machine
 - ◆ When the top unit is opened.
 - ◆ When an original is set in or removed from the ADF.
 - ◆ On initiation of fax operations, such as fax reception, lifting the headset etc.
 - ◆ On initiation of PC printing.
- When a key on the operation panel is pressed to turn the heater on, the key does not perform its normal function.
- After the heater is turned back on, the previous %, quantity, Sort settings, entered fax number, original type and various other settings are cleared.

Changing the Economy Mode

Hold down the Clear modes key for approximately 1 second until the Economy mode indicator lights or goes out, as required.

Economy Mode ON

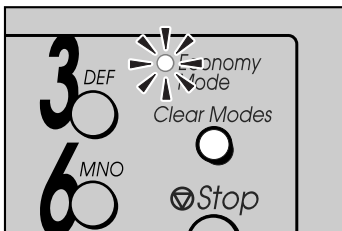

Economy Mode OFF

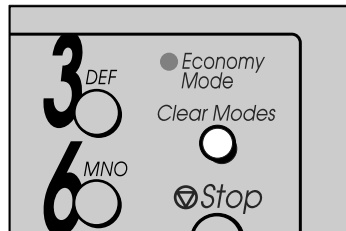

9. SPECIFICATIONS

General Specifications

Paper Capacity

Upper tray
plain paper (80 g/m²: 20 lb.) 100 sheets

Optional paper unit
plain paper (80 g/m²: 20 lb.) 250 sheets

ADF (Auto Document Feeder) Capacity
plain paper:

A4, IT-LG (80 g/m²: 20 lb) 10 sheets

Output tray
plain paper (80 g/m²: 20 lb.) 50 sheets

Memory

4 MB (Expandable to 8 MB, 16MB or 32MB)
EDO SIMM, 60 ns, 72 pin

Dimensions

297mm × 352mm × 576mm (H× W× D)
11.70" × 13.87" × 22.69" (H× W× D)

Weight

15.5 kg (34.18 lb)

Power Supply

120 V
60 Hz

Power Consumption

Max	640 W
Printing (Average)	230 W
Copying (Average)	250 W
Stand-by (Average)	75 W
PC-Scan (Average)	75W
Sending Faxes (Average)	75W
Receiving Faxes (Average)	230 W
Economy Mode	15 W

Operating Environment

Temperature /Humidity
10°C (50°F) to 35°C (95°F)
15% to 80%

Machine Life

30,000 sheets/5 years

Printer Duty

6,000 sheets/1 month

Scanner Duty

2,000 sheets/1 month

Paper Sizes

Plain paper
Letter (IT) = 8¹/₂" × 11"
Legal (LG) = 8¹/₂" × 14"
Half Letter = 5¹/₂" × 8¹/₂"
A4 = 210 mm × 297 mm
A5 = 148 mm × 210 mm
F4 = 8¹/₄" × 13"

Envelopes

Executive = 7¹/₄" × 10¹/₂"
Com 10 = 4¹/₈" × 9¹/₂"
Monarch = 3⁸/₇" × 7¹/₂"

Other

Transparencies
Label paper

Printing Specifications

<p>Printer Language PCL 5e compatible</p> <p>Print Resolution 600 dpi × 600 dpi 1200 dpi × 600 dpi (enhanced)</p> <p>Print Speed 6 ppm (pages per minute)</p> <p>Paper/Media Types Plain paper Envelopes Transparencies Label paper</p> <p>Paper Weight 60 to 90 g/m² (16 to 24 lb)</p> <p>Interface IEEE 1284</p>	<p>Resident Font</p> <ul style="list-style-type: none"> • Dutch 801 SWC • Dutch 801 Italic SWC • Dutch 801 Bold SWC • Dutch 801 Bold Italic SWC • Swiss 742 SWC • Swiss 742 Italic SWC • Swiss 742 Bold SWC • Swiss 742 Bold Italic SWC • Swiss 742 Condensed SWC • Swiss 742 Condensed Italic SWC • Swiss 742 Condensed Bold SWC • Swiss 742 Condensed Bold Italic SWC • Incised 901 SWC • Incised 901 Italic SWC • Incised 901 Bold SWC • Fixed Pitch 810 Courier Roman SWC • Fixed Pitch 810 Courier Bold SWC • Fixed Pitch 810 Courier Italic SWC • Fixed Pitch 810 Courier Bold Italic SWC • Fixed Pitch 850 Letter Gothic 12 pitch/text SWC • Fixed Pitch 850 Letter Gothic Bold 12 pitch/text SWC • Fixed Pitch 850 Letter Gothic Italic 12 pitch/text SWC • Flareserif 821 SWC • Flareserif 821 Extra Bold SWC • Ribbon 131 SWC • Wingbats SWM
---	---

Scanner Specifications

<p>Configuration Flatbed / ADF</p> <p>Document Size LG, IT, HLT, A4, A5, B5</p> <p>Optical Resolution 300dpi</p> <p>Scanning Resolution 1bit 100 × 100, 150 × 150, 200 × 200, 300 × 300, 400 × 400, 600 × 600 dpi 8bit 300 × 300 dpi</p>	<p>Grey scale 256 levels (8-bit)</p> <p>Interface IEEE 1284 ECP mode</p> <p>Compatibility TWAIN</p> <p>ADF Up to 10 pages of 80g /m²(20lb), Plain paper</p> <p>Maximum scanning size 212 × 351.6 mm</p> <p>OS Windws 95/98 only</p>
--	--

Copying Specifications

<p>Copy Speed 6 cpm (copies per minute)</p> <p>Warm-up Time 30 seconds or less</p> <p>First copy 17 seconds or less</p> <p>Multitple Copies Up to 99 copies</p> <p>Copy Reduction and Enlargement 50%, 65%, 77%, 93%, LGL ► ITR 121%, 129%, 155%, 200%, ITR ► LGL</p> <p>Paper/Media Types Plain paper Envelopes Transparencies Label paper</p>	<p>Paper Weight 60 to 90 g/m² (16 to 24 lb)</p> <p>Original Types Exposure glass Sheet/Book ADF Up to 10 pages of 80g /m² (20lb), Plain paper</p> <p>Maximum Original Size Legal (LG) = 8 1/2 " × 14"</p> <p>Copy Resolution 600 dpi × 600 dpi</p>
---	--

Fax Specifications

<p>Modem Speed 14400 bps</p> <p>Protocol ITU Group 3</p> <p>Compression Method MH/MR/MMR</p>	<p>Fax Resolution Text (Standard) :203 × 98dpi Text Fine (Detail) :203 × 196dpi</p> <p>Quick Dials 5</p> <p>Name Dials 25</p>
---	--

INDEX

- I**
- 1 to 1 Copy 70
- A**
- Additional printer 16
- Auto image density 77
- Automatic Document Feeder (ADF) x
- Setting an original 78
- Authorized reception 47
- Automatic redial 45
- B**
- Book Copy 72
- Busy indicator xiii
- C**
- Canceling automatic redial 45
- Canceling transmission of a fax 45
- Changing On/Off settings 68
- Check display indicator xiii
- Clearing a paper misfeed 93
- Clear key xii
- Cleaning pad 97
- Computer port xi
- Connecting a second printer
(Additional Printer) 16
- Connecting to a computer 7
- Connector 16
- Copy operation 29
- Corner guides 17, 19
- D**
- Daily maintenance 96
- Date and time 38
- Density key xiii
- Dial mode 34
- Display xii
- Document guides x
- Document output tray xi
- Installing 5
- E**
- Economy mode 108
- Economy mode/Clear modes key xii
- Economy mode indicator xii
- Enlarge key xiii
- Enlargement 33
- Entering numbers 30
- Entering pauses 43
- Entering tones 43
- Envelopes 14
- Error messages 86
- Error report 65
- Exposure glass x
- F**
- Fax/Copy key xii
- Fax mode 46
- Fax operation 29
- Front guide 17, 20
- H**
- Help list 101
- Help/Function xii
- I**
- Image density 77
- Installing
- Document output tray 5
- Software drivers 25
- Toner cassette 2
- Upper paper tray 6
- L**
- Label paper 15
- Language 107
- Limit mark 11, 17, 19
- Lines-slow (4800 bps) 67
- Loading Paper 11

- Loading
 - Plain paper 11
 - Small size paper 13
 - Other media 15
- Location 1
- M**
- Metal plate 17, 19
- Multiple copies 71
- N**
- Name key xiv
- Name Dials
 - Deleting Name Dial 61
 - Dialling Name Dial 62
 - Storing Name Dial 59
- Numeri keypad xii
- O**
- OK key xiii
- On hook 52
- On hook dial key xiv
- Operation Panel x, xii, xiv
- Original
 - Setting (Exposure glass) 41, 70
 - Setting (ADF) 40, 78
 - Requirements (ADF) 79
- Original guide x
- Original type select key xiii
- Output tray x
- Output tray extension x, 6
- P**
- Page header 68
- Paper and other media 10
- Paper select key xiii
- paper size
 - Changing 20
 - Specifying (upper) 13, 15
 - Specifying (lower) 19
- Paper size indicator 17, 19
- Paper feed unit 17
- Pause/Redial key xiv
- Pauses 43
- PC Interface indicator xiii
- Photo1 76
- Photo2 76
- Platen cover x
- Power socket x
- Power switch x
- Printer driver
 - Windows 95/98 26
 - Windows 3.1 26
- Printer driver contents 27
- Printing the dial list 64
- Printing the journal 63
- Power failure report 65
- Q**
- Quick Dials
 - Clearing Quick Dial 58
 - Editing Quick Dial 56
 - Storing Quick Dial 55
- Quick Dial key xiv
- R**
- Receive file indicator xiv
- Receiving faxes 46
- Reception mode key xiv
- Redialing a number 44
- Reduce key xiii
- Reduction 73
- Remote change 52
- Replacing
 - Toner cassette 91
 - Cleaning pad 91
- Resolution/Photo setting 76
- RDS 68

S

Safety information i

Scanner lock x

 Unlocking 4

Second (Additional) printer xi

 Connecting 16

 Using 28

Second printer key xv

Sending faxes 40

Setting up

 Connecting to the telephone line 32

 Software drivers 25

Side guide 17, 20

SIMM cover x

SIMM 23

Small size paper feed access panel x

Small size paper 13

Sort 80

Sort/Memory key xiii

Sounds 66

Specifications 109

Start key xii

Stop key xii

Storing your own fax number 36

Storage 100

Summer time 39

T

TEL/LINE xi, 32

Tel mode 46

Telephone call 50

Text fine 76

Toner cassette

 Installing 2

 Replacing 91

Tones 44

Top release lever x

Top unit x

Transmission result report 64

Transparencies 15

Troubleshooting 82

TTI 33

U

Unauthorized call report 65

Upgrading memory 23

Upper paper tray x, 6, 11

Upper try extension xi

User parameter 103

Using the second (Additional) printer 28

Z

Zoom key xiii

Zoom (In 1% increments) 75